

VEO & VE04K CAMERAS

340 | 640 | 410 | 710 | 590 | 990 | PL | S and L Models

VEO MANUAL

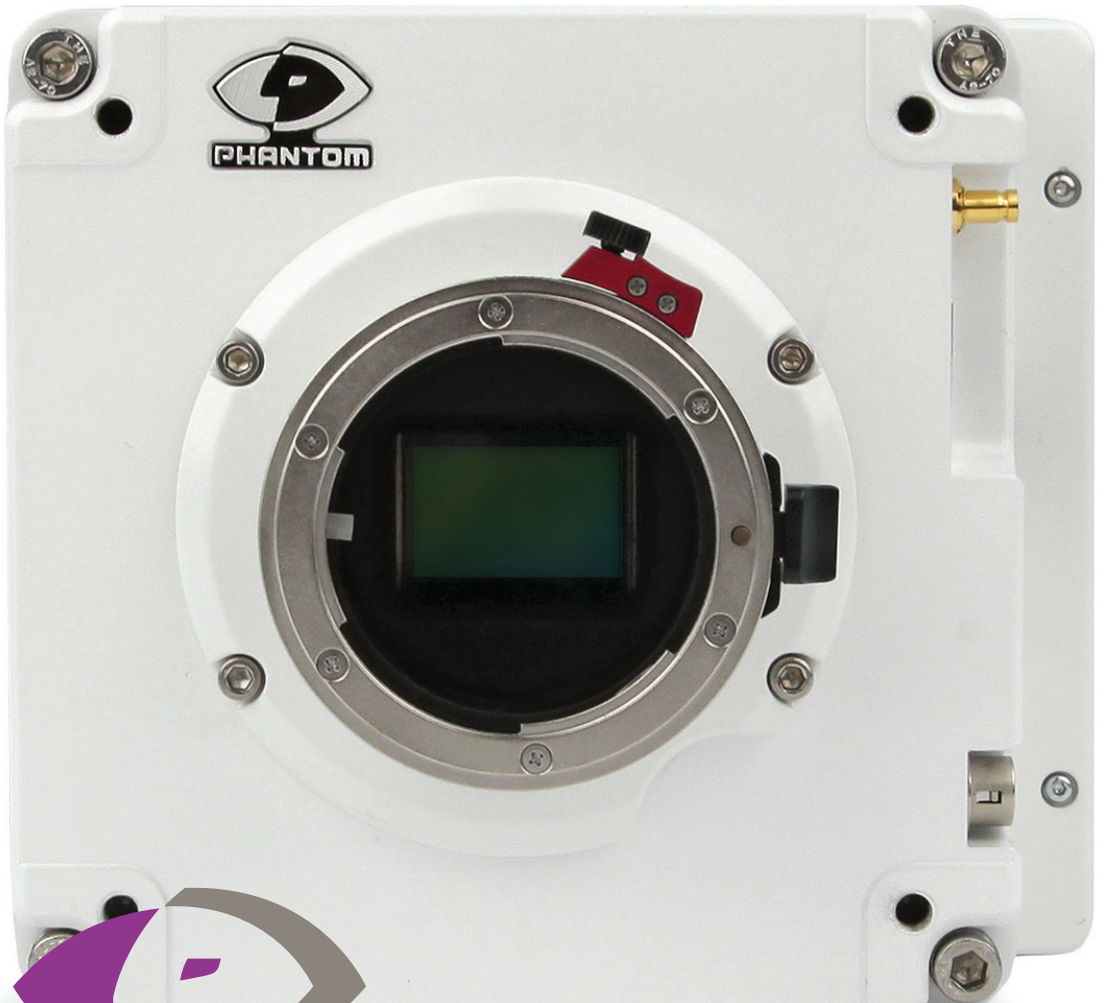

When it's too fast to see, and too important not to.®

PHANTOM[®]

ViSiON
RESEARCH

AMETEK[®]
MATERIALS ANALYSIS DIVISION

www.phantomhighspeed.com

Phantom VEO

MANUAL

Including models
VEO 340, 640, 410, 710
VEO4K 590, PL, 990
S and L body styles

www.phantomhighspeed.com

Written and produced by the Marketing Department at Vision Research.

The contents of this manual may be subject to change without notification.

PN: ZDOC-64109-MA-0001 Rev B
Last Updated: January 2018

Contents

1	Camera Overview	1
2	Connectors	5
3	Network Setup & Quick Start Guide; Includes 10Gb Ethernet instructions	9
4	On-Camera Controls and On-Screen Displays	15
5	Working with CFast 2.0 Cards	27
6	Phantom PCC Software: Camera Operation, Download and File Conversion	31
7	Programmable I/O Signal Architecture	45
8	Measurements with PCC	51
9	Accessories	57
10	FAQs & Support	67

specifications

	VEO 710 VEO 410	VEO 640 VEO 340	VEO4K 990 & PL VEO4K 590
Max. Resolution	1280 x 800	2560 x 1600	4096 x 2304
FPS @ Max Res	7400 fps (710); 5200 fps (410)	1400 fps (640); 800 fps (340)	938 fps (990); 530 fps (590)
Throughput	7Gpx/sec (710); 5Gpx/sec (410)	6Gpx/sec (640); 3Gpx/sec (340)	9Gpx/sec (990); 5Gpx/sec (590)
Sensor Size @ Full Res	25.6 x 16 mm (super 35mm)		27.6 x 15.6 mm
Pixel Pitch	20 micron	10 micron	6.75 micron
CAR	64 x 8	128 x 4	4096 x 4
Min. Exposure	1 µs standard, 300ns optional on 710 models only		5.6 µs
Straddle Time	395 ns (710); 480 ns (410)	1.73 µs (640); 1.71 µs (340)	7.5 µs (typical) 3.7 µs w/ GS & PIV mode
Native ISO (12232 SAT Method)	Mono: 6400 Color: 2000	Mono: 6400 Color: 1250	Mono: 2500 (GS); 1000 (RS) Color: 640 (GS); 320 (RS)
Recommended Exposure Index (E.I.)	Mono: 6400 - 40,000; Color: 2000 - 10,000	Mono: 6400 - 40,000; Color: 1250 - 6400	Mono: 4000 - 8000 (RS/GS) Color: 800 - 1000 (RS/GS)
Memory	18GB, 36GB or 72GB RAM		36GB or 72GB RAM
Power	16-32 VDC primary power, power supply included. Secondary 12V input on S-models only		
Size/Weight	Approx. 5 x 5.5 x 5 in (12.7 x 12.7 x 12.7 cm) 5.6 lbs (2.5 kg)		Approx. 5 x 5.5 x 6 in (12.7 x 14 x 15 cm) 6.5 lbs (2.9 kg)
Operational Temp	-10° - +50° C		
Shock Rating	Rated 30G (standard); 100G without shutter (optional)		

	Ethernet	Video	OCC/ Buttons	CFast Media	Programmable I/O	Range Data
'L' style	1 GbE with 10GbE option, RJ45 port	Front 3G SDI Din & HDMI	None	None	2 Ports	None
'S' style	1 GbE with 10GbE option, Fischer port	Same as L w/ additional 3G SDI BNC	Full OCC menu + Trigger & Play buttons	Supports CFast 2.0 cards up to 256G	4 Ports	Yes, Dedicated Fischer port

1 | Camera Overview



Phantom VEO 340L and 710S

Introduction

Phantom VEO high-speed cameras are small, rugged, packed full of features and available in several performance levels and two body styles (L and S).

VEO 410 and 710 models use a one-megapixel sensor. At 1280 x 800 the VEO 410 captures over 5,000 frames per second (fps) and the VEO 710 goes over 7,000 fps.

Like all Phantom cameras, the lower the resolution the faster the camera can record. At 720p the VEO 710 reaches 8,000 fps. With the fast option installed the VEO 710 records over 1,000,000 fps at a reduced resolution.

The Phantom VEO 340 and 640 use a four-megapixel sensor. The VEO 640 goes over 1,400 fps at full resolution and over 2,500 fps at 1920 x 1080.

VEO4K cameras utilize a 9.4-megapixel sensor. PL and 990 models will capture up to 1,000 fps at 4K resolution.

Sensitivity & Exposure Index

VEO cameras use proprietary 12-bit CMOS sensors designed for optimal image quality and light sensitivity. The camera's Exposure index function allows for the effective ISO to be dialed in either on the camera body or in PCC software.

This function applies pre-defined tone curves to the image, providing an apparent boost to the ISO while maintaining image integrity across the full tonal range.

VEO4K models are configured to capture images using either a Rolling Shutter or Global Shutter. Global Shutter mode has a higher base-ISO than Rolling Shutter (640 vs 320). By using the Exposure Index function both modes can capture at the same ISO level, and the factory recommendation is between 800-1000 EI for color cameras in both modes.

Lens Mounts

All models have a super 35mm field of view at full resolution and are compatible with common SLR lenses when equipped with the standard Nikon or optional Canon EF lens mount. The Canon mount allows for electronic and remote control of aperture and focus. A PL mount and C-mount are also available for VEO cameras.

Camera Control

All Phantom VEO cameras come with PCC software for setup and control over an Ethernet network. VEO S-model cameras also have an On-Camera Control (OCC) menu system for use with an attached video monitor. The OCC menu can adjust both basic and advanced camera settings. Capture, Play and Save-to-CFast functions are also available via the camera's OCC menu.

CFast 2.0 Workflow

VEO S-model cameras are compatible with standard CFast 2.0 cards. CFast cards are non-volatile, hot-swappable recording media and they enable remote, un-tethered recording. The cards must be formatted with the NTFS file system - this can be done either in-camera or in a CFast 2.0 card reader on a PC or Mac.

Once images have been captured in RAM they can be played back immediately, in/out points set and then saved to the CFast card at speeds of approximately 90 MB/second.

File Formats

Like all Phantom cameras, Phantom VEO utilizes Vision Research's proprietary Cine Raw format. These files are captured in 12-bit and efficiently saved to the CFast 2.0 card in a 10-bit 'packed' format.

Cine Raw files can be viewed and edited in PCC software, where basic motion analysis measurement tools are available. An SDK and file format documentation are available for users who require Phantom Cine file compatibility in independent software.

Cine Raw files are compatible with many of the video industry's top editing programs, or they can be converted to a variety of formats (h264 .mp4, Apple ProRes .mov, .avi, tiff, etc) using software provided with the camera.

All Phantom VEO camera models have a 3G HD-SDI, HDMI and 12V power output from the side of the camera. These make it easy to use a small on-camera monitor or viewfinder for composing the shot and watching a smooth playback without being tethered to a computer.

VEO S-models have a second 3G HD-SDI BNC port on the back of the camera. The feed from all video outputs is identical and can show either live video or playback.

Image Monitoring & Video Outputs

Additional Features

10Gb Ethernet Option: The fastest way to download data from from RAM

Programmable I/O: Assign and Define signal parameters. See Programmable I/O section for more info.

Image-Based Auto-Trigger (IBAT): Trigger camera from change in image

Multi-Cine: Support for up-to 63 partitions

Burst Mode: Generate a precise number of frames with every frame sync pulse. This feature is not available with VEO4K models.

Continuous Recording: Automatically and continuously save Cines to external storage

VEO-L

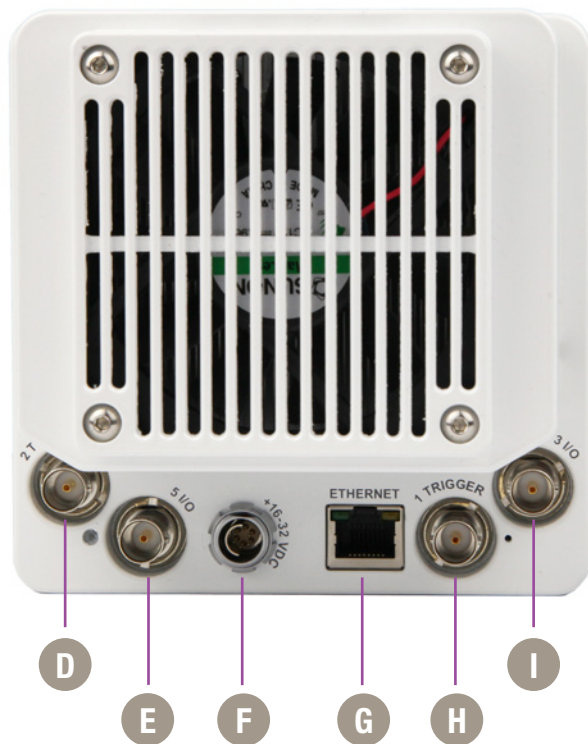
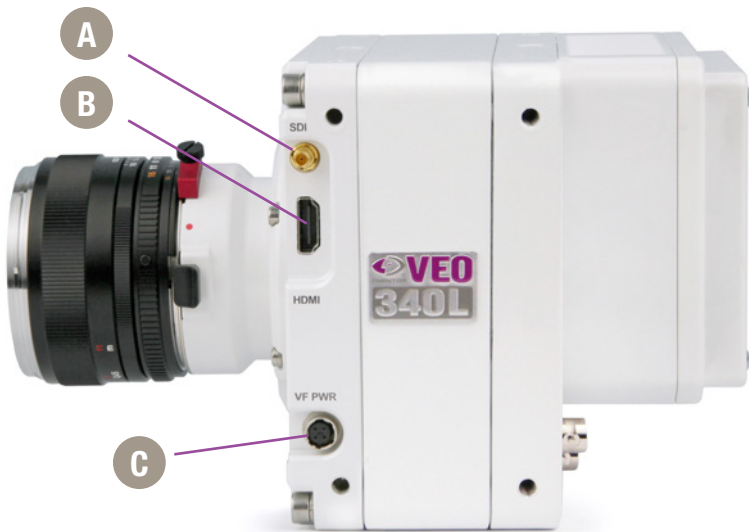

Phantom VEO-L Models - Side and Rear Views

2

Connectors VEO-L Models

SDI	A	Din (mini-bnc) connector outputs SDI video at 1.5G and 3G video rates.
HDMI	B	Standard HDMI connector - outputs identical digital video signal as SDI.
VF PWR	C	4-pin Hirose port. +12V power output for small monitors and viewfinders, rated up to 10W.
2 TC In	D	Timecode-in BNC - fixed port.
5 I/O	E	Programmable I/O BNC port. Port ID = P5 Default signal is Strobe.
+16 - 32 VDC	F	6-pin Fischer port for main power input, accepts +16 - 32 VDC.
Ethernet	G	RJ45 port for Gb Ethernet, for control and data transfer.
1 Trigger	H	Trigger-in BNC - fixed port.
3 I/O	I	Programmable I/O BNC port. Port ID = P3 Default signal is F-Sync.



Assign and define **Programmable I/O** ports using PCC.

Instructions can be found in the Programmable I/O section of this manual.



A complete cable connector reference and pin-out guide is available in the last section of this manual

VEO-S

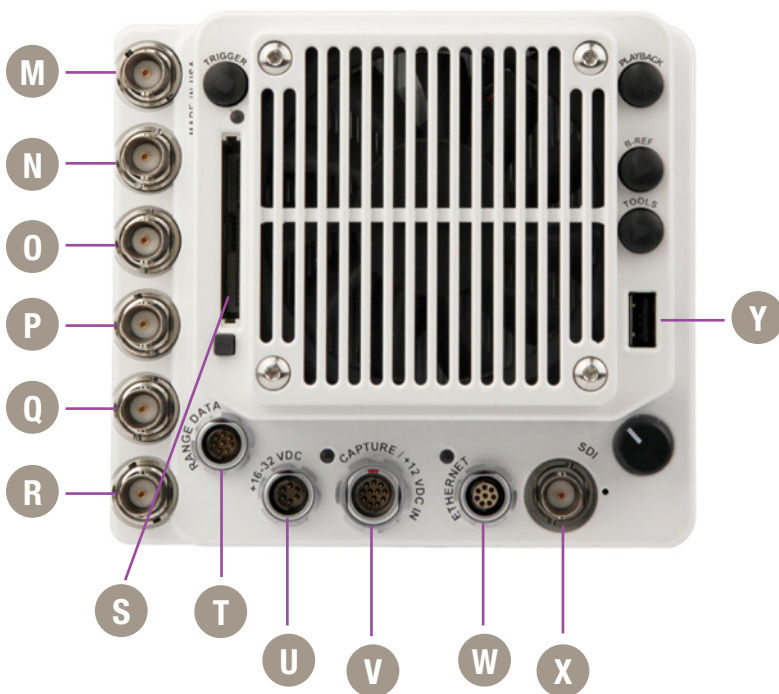
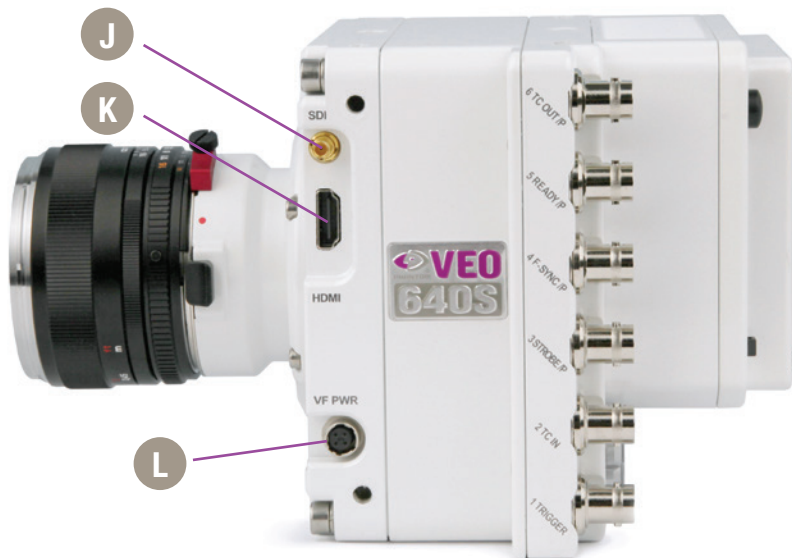

Phantom VEO-S Models - Side and Rear Views

VEO-S Models

SDI	J	Din (mini-bnc) connector outputs SDI video at 1.5G and 3G video rates.
HDMI	K	HDMI video output.
VF PWR	L	4-pin Hirose port. +12V power output for small monitors and viewfinders, rated up to 10W.
6 TC Out /P	M	Programmable I/O BNC port. Port ID = P6 Default signal is Timecode Out.
5 Ready /P	N	Programmable I/O BNC port. Port ID = P5 Default signal is Ready.
4 F-Sync /P	O	Programmable I/O BNC port. Port ID = P4 Default signal is F-Sync.
3 Strobe /P	P	Programmable I/O BNC port. Port ID = P3 Default signal is Strobe.
2 TC In	Q	Timecode-in BNC - fixed port.
1 Trigger	R	Trigger-in BNC - fixed port.
CFast Port	S	CFast 2.0 Card slot.
Range Data	T	8-pin Fischer port for Range data input.
+16 - 32 VDC	U	6-pin Fischer port for main power input, accepts +16 - 32 VDC.
Capture / +12VDC In	V	12-pin Fischer port for capture cable or mini-bob accessories, or use as a secondary +12V power input for battery adapters.
Ethernet	W	8-pin Fischer port for Gb Ethernet, for control and data transfer.
SDI	X	BNC port for 1.5G and 3G SDI video output.
USB Port	Y	USB port - For WiFi dongle (Requires chipset RT5370)



This section shows basic setup and camera control using Phantom PCC software. More in depth instructions can be found later in this manual. Please note there are other methods of camera control including on-camera controls, the Phantom Remote Control unit (RCU) and various 3rd party solutions.

3

Network Setup & Quick Start Guide

Gb & 10Gb Ethernet

Phantom cameras are typically controlled with PCC software through a dedicated Ethernet network. PCC is compatible with the 32 and 64-bit versions of Windows 7 Pro, Windows 8.1 and Windows 10 operating systems. The latest version can be downloaded at:

www.phantomhighspeed.com/pcc

All VEO cameras come with standard Gigabit (Gb) Ethernet and have the option to be configured with 10-Gigabit (10Gb) Ethernet as a secondary means of connection. With 10Gb Ethernet, the VEO can achieve significantly higher download speeds which makes it a great option for saving large files quickly out of RAM.

VEO cameras have one Ethernet port which handles both protocols. The camera will auto-negotiate the connection speed based on the computer's network card and its IP configuration as described later in this section.

First, check to see if your VEO has the 10Gb Ethernet option installed by looking at the **Serial Number and IP Address** label on top of the camera. If installed, '10G' will be printed on the label, in addition to an 'XIP' address that begins with 172.16 as pictured.



Assigning a Gb Camera Network

Connecting the VEO with standard Gb Ethernet is straight forward, as virtually all computers will be compatible with no special equipment or drivers involved. The main thing that needs to be done is to re-assign the network settings of the Ethernet port to detect the IP address range of Phantom cameras.

10Gb Ethernet

Step 1: Identify network adapter

1. In the Windows **'Network and Sharing Center'** select the camera network, this opens the **'Ethernet Status'** window (Note: For Laptops without a built-in RJ45 port the adapter may have to be physically connected before selecting the network)
2. Change the Ethernet IP settings by selecting **'Properties'**, then **'TCP/IPv4 'Properties'**, then select **'Use the following IP address,'**
3. Enter:
 - **IP address: 100.100.100.1**
 - **Subnet mask: 255.255.0.0**All other settings should be empty
Click **'OK'**
4. Ensure the Windows Firewall is disabled for this connection

You can now start PCC, which should recognize the connected camera in the Manager tab. If you are not working with 10Gb, skip to the 'Capturing a Cine' section below.

On cameras with the 10Gb Ethernet option, the first step to working with this feature is to identify a **10GBase-T** network card or adapter for the computer itself.

For desktop (tower) PCs Vision Research specifically recommends the **Intel X540-T2** PCIe card.

Laptop computers must have a **Thunderbolt** connection available in order to take advantage of one of the many Thunderbolt → 10Gbase-T converters on the market. At the time of writing, the recommended converter is the **Promise Sanlink2 10Gbase-T** converter (part # SLE2002TNAA). This device has 2 Thunderbolt 2 ports. This means if your computer has a newer Thunderbolt 3 connection a secondary adapter is required to convert the Thunderbolt 2 to a Thunderbolt 3 port. For this, the **StarTech Thunderbolt 3 to 2** adapter is recommended (part # TBT3TBTADAP).

Note: At the time of writing, the newer Sanlink 3 is not fully compatible with Phantom products. Other devices have tested well, including the Sonnet Twin 10G Thunderbolt 3 converter (part # SOTWIN10TB3), however the Sanlink 2 is physically smaller.

Step 2: Install device driver

Once the network card or converter is connected, the next step is to install the latest device driver from the manufacturer's website. The camera should be powered on and connected during the driver installation. After the driver is installed, reboot the PC.

A new, unidentified camera network should now be available in the Windows Network and Sharing Center.

Step 3: Install PCC with 10Gb Phantom driver

The latest version of PCC software should now be installed from the disk that came with the camera or by running the setup.exe file within the package downloaded (and extracted) from www.phantomhighspeed.com/pcc

Click through the prompts, and be careful to click **'YES'** when the program prompts you to install the 10 Gigabit Ethernet Driver.

Step 4: Assigning a 10Gb Camera Network

Just like assigning the 100.100 IP range for standard Gb Ethernet, the Phantom 10Gb Ethernet network needs to be assigned to work in the 172.16 IP range. The camera should be powered on and physically connected to the 10Gb network card or Thunderbolt adapter.

1. In the Windows **'Network and Sharing Center'** select the camera network. This opens the **'Ethernet Status'** window.
2. Change the Ethernet IP settings by selecting **'Properties'**, then **'TCP/IPv4'** **'Properties'**, then select **'Use the following IP address,'**
3. Enter:
 - **IP address: 172.16.0.1**
 - **Subnet mask: 255.255.0.0**All other settings should be empty
Click **'OK'**
4. Ensure the Windows Firewall is disabled for this connection

Capturing a Cine

Now that the camera network is set up (via Gb or 10Gb Ethernet), the following steps will guide you through a simple capture and save process.

Launch PCC Software

Double-click the PCC icon located on the desktop. Camera should be recognized immediately if connected and network settings are correct.

Select Camera for Use

In the 'Manager' tab, double-click the Phantom camera to be used from the 'Cameras' group folder.

Click the 'Live' tab.

Define Recording Parameters

Click 'Cine Settings' and define the following parameters by either selecting the value from the pull-down selection list, or type a value into the respective data entry field.

1. Set 'Resolution' to the required Width x Height
2. Choose the required 'Sample Rate', 'Exposure Time' and 'Exposure Index'
3. Ensure the EDR (Extreme Dynamic Range) is set to zero (0).
4. Set Post Trigger to zero (0) by:
 - a. Moving the 'T' (Trigger Position) slider to the right, or
 - b. Enter zero (0) into the 'Last' data entry field.

Click on the CSR button to perform a Current Session Reference.

With color cameras, perform a White Balance by right-clicking an area of the image that is neutral gray or white, as long as it is not 100% saturated.

Fine-tune Settings

After CSR and White balance are performed, adjust settings, aperture and/or lighting to get a good exposure. A CSR must be performed after any camera settings are adjusted.

'Arm' Camera

Click the 'Capture' button to start recording to the camera's internal RAM memory (circular buffer).

Trigger

At the end of the action, click the 'Trigger' button at the bottom of the 'Live' panel, or provide a switch closure or an external trigger signal (TTL pulse) via the Trigger connector.

Playback and Edit Cine

Click the 'Play' tab.

Scrub through the timeline or use the Video Control Buttons to locate the first image to be saved.

Click the 'Mark-in' button. 

Locate the last image of the cine to be saved.

Click the 'Mark-Out' button. 

Review Edited Cine

Select 'Play, Speed & Options' and enable (check) 'Limit to Range'.

Under the Video Control Buttons, click the 'Jump to Start' button and review the edited cine using the Video Control Buttons.

Save to Computer

Click the big 'Save Cine...' button on the bottom of the 'Play' panel.

In the 'Save Cine' window:

1. Navigate to the folder where you want to save the cine file.
2. Enter a file name for the cine file in the 'File name:' data entry field.
3. From the 'Save as type' pull-down selection list, select the 'Cine Raw, *.cine' file format.
4. Click the Save button to begin downloading the cine file from the camera.

Save to CFast (optional)

Click the down-arrow of the 'Save Cine...' button.

Select 'Save RAM Cine to Flash' (in popup window).

Click the Save button to save the cine file onto the CFast 2.0 card

Confirm Flash Cine Save before deleting from internal memory. Select the new Flash Cine from the top Play/Cine drop-down list and scrub through cine file to review.

Confirm Computer Save

Click the 'Open File'  button

Navigate to the folder and open saved cine file. Review the playback by scrubbing through the file and viewing the playback.

VEO-S OCC

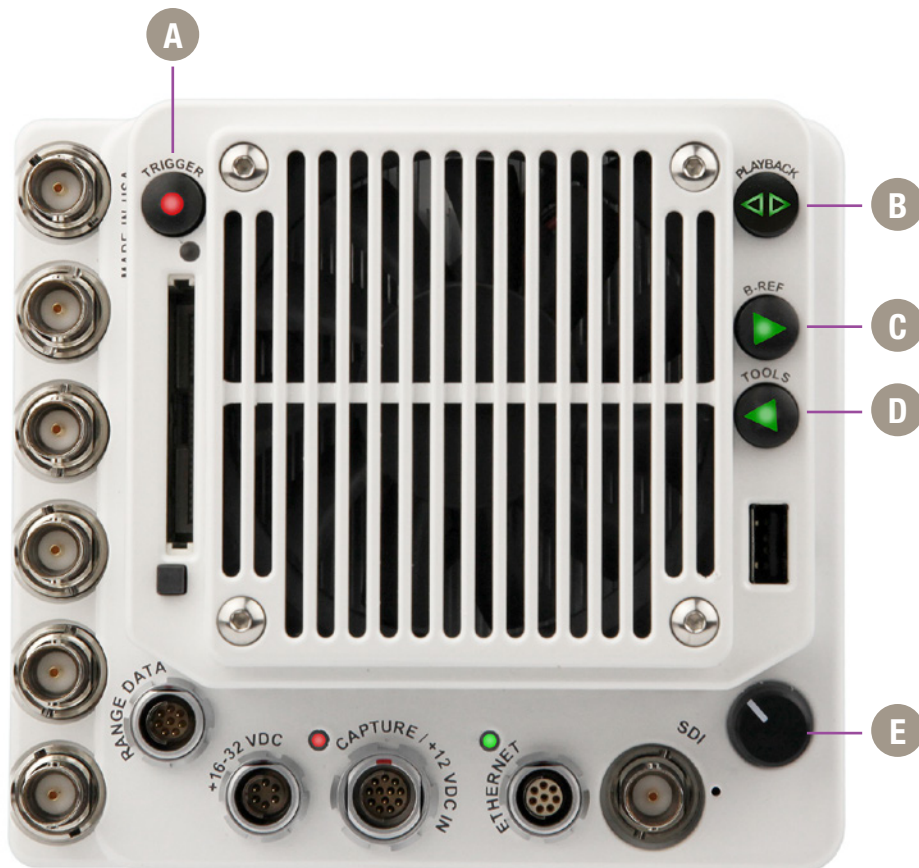

Use of the VEO-S on-camera control menu requires a video monitor to be connected to the camera. VEO cameras are compatible with HDSDI and HDMI monitors.

The combination of a VEO battery mount, a small camera-powered on-camera monitor and CFast cards creates a fully portable, un-tethered camera system. More details can be found in the accessories section of this manual or at www.phantomhighspeed.com

4

On-Camera Controls

Trigger

A

When camera is in capture mode (writing to internal RAM), button glows red. Trigger is used to trigger the camera with a single tap. When a Cine is captured, button glows green.

When in video playback mode, tap the trigger button to return to a live video output.

When menu is active, tap the trigger button to exit the menu.

To clear previous recording from RAM and re-enter capture mode, hold down the trigger button for 4 seconds.

Playback

B

Tap to enter playback mode when a cine is stored in RAM. Playback buttons will glow green when camera is in playback mode.

B-Ref

C

In live mode, a long press of the B-Ref button will perform a Current Session Reference (CSR). When in playback mode, the play-forward symbol is illuminated and this button is used to play forward. A long press will do a fast-forward. Tap to pause.

Tools

D

In live mode, a tap of the Tools button will cycle through video zoom levels (for focus assist) and threshold (exposure assist) mode. When in playback mode, the play-backward symbol is illuminated and this button is used to play reverse. A long press will do a fast-reverse. Tap to pause.

Menu Knob

E

Tap the menu button to activate the camera's menu system as described on the following pages. Turn the knob to navigate through the menu, and tap to select. Exit the menu by waiting 10 seconds or tapping the trigger button.

OSD Overview



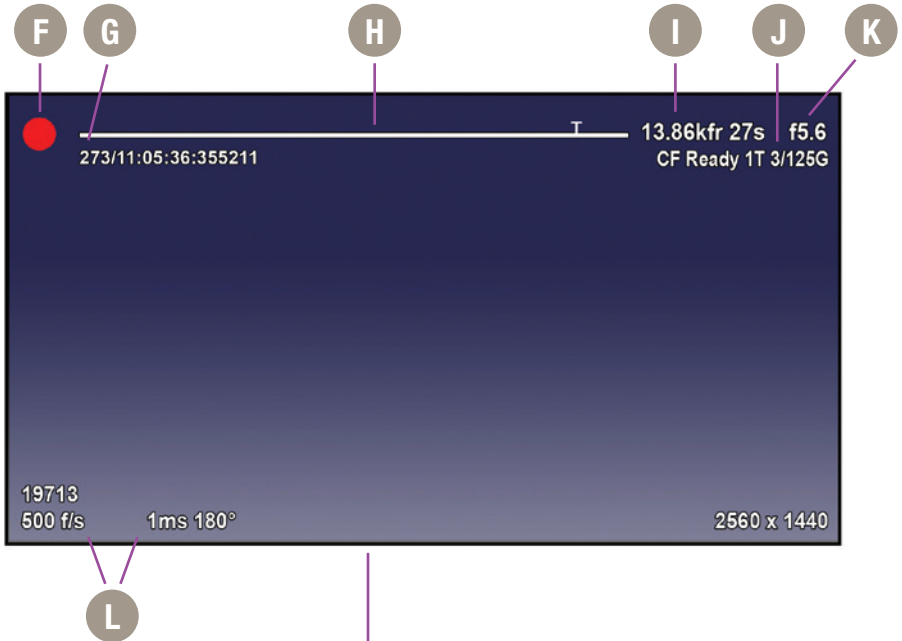

The On-Screen Display (OSD) provides valuable information about the camera's current status over the video outputs along with the live or playback images.

Video display, Live mode

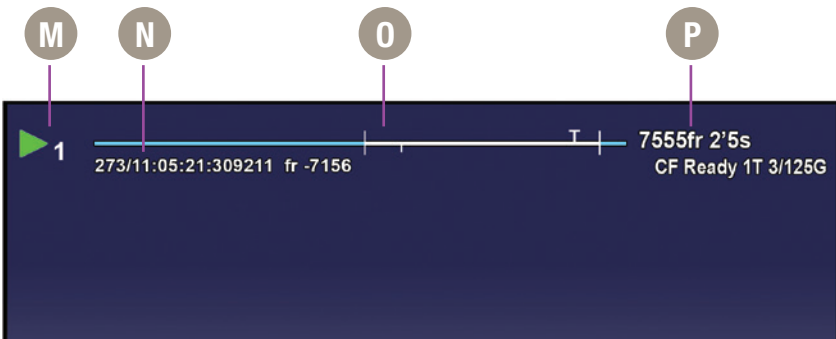

Video display, Playback mode



Camera State	F	The symbol changes based on camera's state:
		Live: The camera is not recording and a live image is displayed from all SDI ports.
		Capture: The camera is recording to internal memory (RAM), and awaiting a trigger signal.
		Triggered: The camera has been triggered, and is filling RAM memory ('Post-Trigger' frames).
		Cine Stored: Recording has ended, and a Cine is stored in RAM memory. This Cine must be erased from the RAM to begin recording again.
		Playback: The camera is in PLAYBACK mode. RAM Cines can be reviewed, edited and saved to flash.
Timecode	G	Indicates the IRIG time code stamped to each frame. Format is day of year/hour:minute:second:ns.
Buffer Bar w/ Trigger Point	H	This 'time line' represents all frames available in camera RAM (Loop mode) The 'T' indicator represents the user-defined trigger point.
Frame Count and Duration	I	Displays the frame count and recording time based on the current camera settings.
Flash Memory Status	J	Indicates the memory size of the CFast card (if present) and the total recording time available.
EF Lens Aperture Data	K	Displays the F-Stop (aperture) of the lens (valid for Canon EF mount only).
Capture Settings	L	Bottom section of display shows camera name, frame rate, exposure time (displayed in degrees and micro-seconds) and the acquisition resolution.
RAM Cine Indicator	M	Indicates RAM Cine number selected for playback.
Playback bar	N	Playback bar is a visual representation of the Cine timeline with the trigger point (T), mark-in and mark-out (I) points and play head indicated.
Playback Timecode	O	Playback timecode shows the timestamp of each frame in IRIG format and the current frame number.
Playback	P	Frame count and playback duration based on current video settings - within the mark-in and mark-out points.

menu system

Menu Overview

The VEO-S On-Camera Control menu provides access to basic and advanced camera settings. The menu is activated with a press of the menu knob and displayed through the camera's video outputs (SDI and HDMI) as a video overlay, on top of the live image.



The menu is subject to change, and functionality may differ based on camera model and firmware level.

Navigation

Activate the menu by pressing the menu knob on the back of the VEO-S camera. Turn the knob to scroll through each menu item and press to select. The six menu pages can be quickly jumped between by selecting the page title (1/6 CAMERA in this example) and scrolling through them.

To exit the menu tap the trigger button. The menu will also turn itself off after a period of time with no interaction.

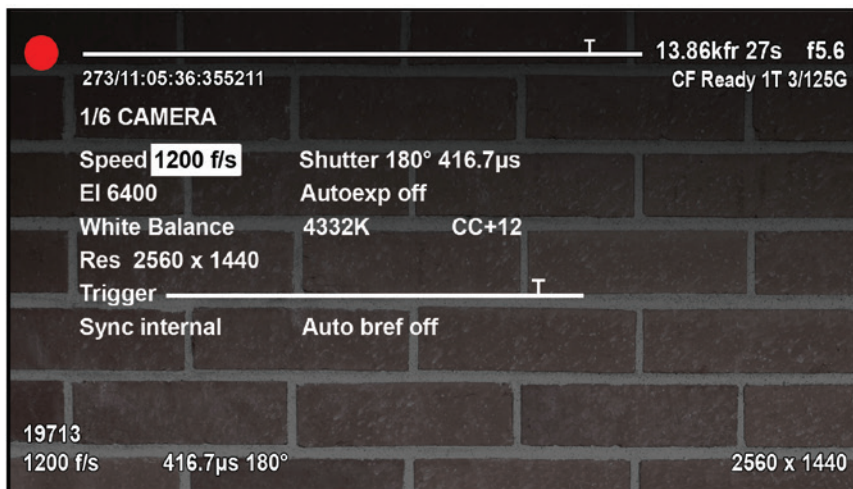

Six Menu Pages

- 1/6 CAMERA
- 2/6 IMAGE
- 3/6 SETTINGS
- 4/6 INFO
- 5/6 AUTO
- 6/6 ADVANCED

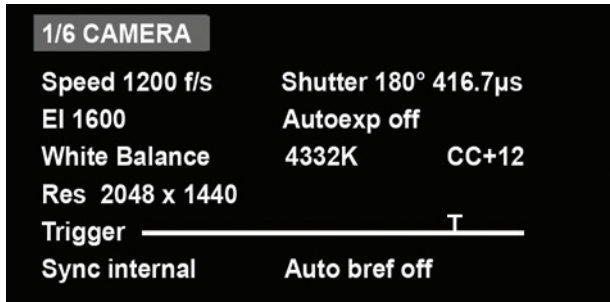

1/6 CAMERA

The CAMERA menu page includes control for the fundamental settings of a high speed camera.

Speed

Set the acquisition frame rate in frames-per-second.

Shutter

Set the exposure time, which is displayed in degrees and time (microseconds in this example).

EI

Set the Exposure Index (EI), also known as the “effective ISO”. The lowest setting is the base ISO of the camera.

Autoexp

Enable autoexposure, which can be useful in the case of changing lighting conditions.

White Balance

For color cameras, set the white balance by placing a white or neutral gray object in front of the camera. Ensure that the white subject is not fully saturated. Select the word ‘White Balance’ and rotate to select “OK”. The color temperature (K) and color compensation (CC) values can be further manually adjusted if required.

Res

Set the acquisition resolution of the sensor.

Trigger

Set the trigger point. The time line represents all frames available in RAM. Frames before the ‘T’ are pre-trigger frames and frames after the ‘T’ are post-trigger frames.

Sync

Changes the frame sync from internal to an external source.

Auto bref

When enabled a black reference will be automatically done every time the camera enters capture mode.

2/6 IMAGE	
Master gamma	2.200
Master gain	1.000
Master black	0.000
PA 0 x 0	PAO 0 , 0
Zoom fit	Color Bars off
Video system	1080/24p
Anamorphic	off

2/6 IMAGE

The IMAGE page allows for control of image processing and video settings. These image settings are adjustments applied to Cine Raw files as metadata. Note: When the camera is set to a LOG output, these adjustments do not apply.

Master gamma

Sets the master gamma, which is the relationship between signal level and brightness output of the image. A linear gamma would have the value of 1.0. The camera's default setting is 2.2 which represents a standard Rec709 gamma curve.

Master gain

Adjusts the overall signal level of the image. Increasing Gain will further increase the Exposure Index of the camera. Vision Research recommends keeping this close to the default setting of 1 for best image quality.

Master black

Adjust the baseline black level. The default of 0 should produce images with black at 0 on a waveform monitor.

PA and PAO

The camera will add a Production Area (PA) with the specified frame size as an overlay on the video image. PAO is the Production Area Offset which will move the Production area from the center of the image both vertically and horizontally. 0 , 0 is the default.

Zoom

Change the zoom level of the video output. Fit will scale a larger or smaller resolution image and optimize it to the size of the video output. A zoom setting of 1 will show the image pixel-to-pixel and a setting of 2 will zoom up 2:1.

Color Bars

Displays SMPTE HD Color bars on video outputs

Video System

Sets the video output to one of the valid video systems. All the common 720p, 1080p, psf and i settings are available. The video outputs will change right away, however the new video system must be confirmed to take effect. If not confirmed it will switch back to its previous setting in a few seconds.

Anamorphic

VEO4K cameras can output 2.0x or 1.33x de-squeezed video compensation for anamorphic lenses. 23.98p, 24p, 25p, 29.9p and 30p video systems are supported.

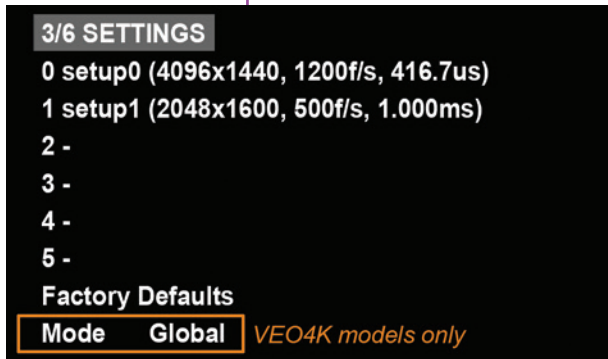

3/6 SETTINGS

The SETTINGS page allows for user setups to be saved and recalled.

0-5

There are six available entries. By selecting one of the slots users can save or recall that particular set-up to quickly change all parameters of the camera at a later date. The values in parentheses are meant as a quick reminder of camera settings.

Please note that all camera settings, including video mode, sync mode, image and advanced settings are included. These settings are saved after the camera powers down.

Factory Settings

Recall the factory defaults to bring the camera back to the original settings from the last time it left the Vision Research factory. This includes all capture, calibration, image processing and video parameters.

This is an important troubleshooting step.

Mode

VEO4K camera models only. This camera can be switched from Global Shutter to Rolling Shutter. Once the desired mode is selected, it must be confirmed twice before the change takes place.

The camera will change modes (the process takes about 20 seconds) and revert to its factory default settings. It is recommended to use the user setup slots (above) to save and recall the previous setup to make mode switching faster.

4/6 INFO

Model: Phantom VEO4K 990S 72G S/N: 10022
Firmware level: 106 (25378, 905503017, 429560)
Sensor: 35° Camera: 54° Fan: 40% TEC: -50%
Default IP Address: 100.100.169.217
User IP Address: -.-.-
10G IP Address: 172.16.19.12

4/6 INFO

The INFO page displays unique information of the camera including:

Model name, memory size and serial number

Firmware level

Current temperature of the Sensor and Camera, and the power of the Fan and the TEC (thermoelectric cooler) of the sensor. This is for monitoring purposes.

Factory-assigned IP, and optional 10Gb IP address of the camera

User-defined IP address (secondary IP) which can be used with an IP range outside of the Phantom 100.100 network. This is set using Phantom PCC software.

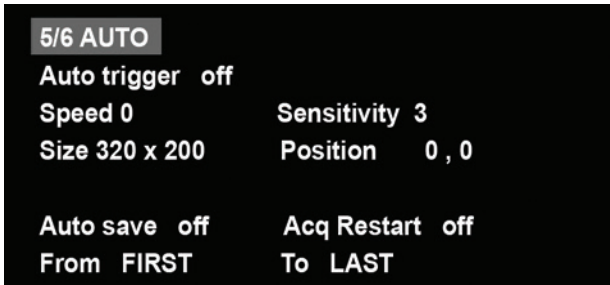

5/6 AUTO

The AUTO menu allows for control of some of the camera's automatic functions.

Auto trigger

Enable the camera's image-based auto-trigger function. When on, the settings for Speed and Sensitivity determine the threshold for the trigger's response time. Vision Research recommends to experiment with these settings before determining what works best for your subject.

The settings for Size and Position define the area in which a change in motion will activate the trigger. A change outside that window will have no effect.

Auto-trigger is not compatible with VEO4K camera models.

Auto save

When auto save is enabled, the camera will automatically save the Cine once triggered to an installed CFast card.

From & To

Used to define the first frame and last frame for the auto save function. By default these are set to the first frame and last frame of the recorded cine.

From & To

When Acquisition Restart is enabled, the camera will automatically start recording again after the auto-save or auto-play functions are complete. This is particularly useful when using multi-cine memory partitions. Be careful to only use this with auto-save (or auto-play with a video recorder), and pay attention to remaining space on the CFast card.

6/6 ADVANCED			
	R	G	B
Gain	1.000	1.000	1.000
Pedestal	0.000	0.000	0.000
Gamma	2.222	2.222	2.222
Color Space	Rec709		
OSD on	CF Format		
Memory partitions			
Frame burst	off	Period 700µs	

6/6 ADVANCED

R G B Gain, Pedestal and Gamma

The ADVANCED page includes settings for either less-used settings or features which should be used with caution.

Set the Red, Green and Blue channels separately for the Gain, Pedestal and Gamma image processing settings. These settings can be used with color cameras to fine-tune the color output. The overall gain, pedestal and gamma functions can be found on the IMAGE page of the menu.

Color Space

Rec709 is the standard gamma curve of all Phantom cameras. The video can switch from Rec709 to Phantom Log 1 and Log 2 curves. This is useful to see the full dynamic range of the image over SDI. Log modes will override all image adjustments including Exposure Index.

OSD On

Turns off (and on) the On-Screen Display video overlay for a clean video feed

CF Format

Erase the entire contents of an installed CFast 2.0 card. VEO cameras employ the NTFS file system. CFast cards that are currently in a different format will not be recognized, however they can be formatted for use with VEO with this function.

Memory partitions

Set the amount of partitions to segment the RAM for multi-cine recording. The RAM is divided evenly, and the same frame rate and recording parameters will apply for each partition.

Frame Burst & Period

Set the number of frames in a burst, which are frames that captured to RAM with every f-sync pulse. 'off' disables burst mode. The period sets the interval between frames in a burst (defined in microseconds).

VEO4K camera models are not compatible with burst mode.

Capture a Cine

Capture a Cine file to RAM

1. Ensure camera is in capture mode (trigger button glows red)
2. Tap the trigger button to trigger the camera once the event happens. Remember, the position of the trigger will depend on the post-trigger setting. With a post trigger set at the end, or '0', the trigger should be applied after the action occurs.

Enter Playback mode

With Cine in RAM, tap the Playback button. The video output will switch to playback view, where you must select the Cine for playback. In the case of multi-cine or partitioned RAM, there will be more than one RAM cine present, as shown here.

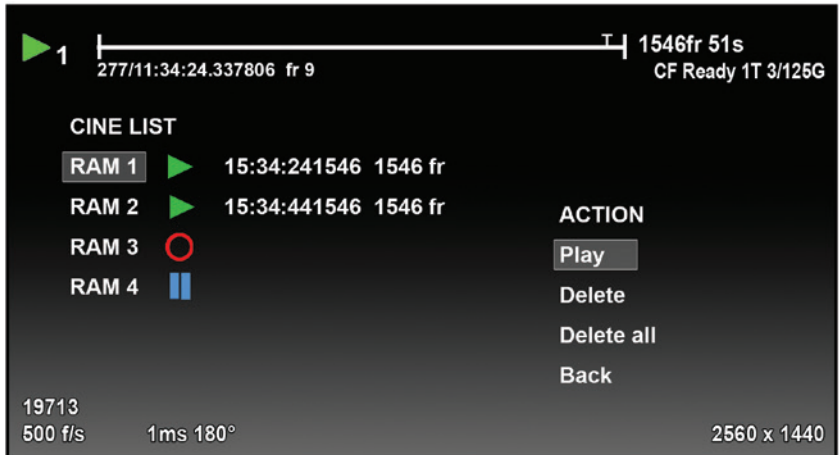

Once the take is selected, there are options to Play, Delete, Delete all, or go back. Clicking play will close the menu and the video begins to play forward.

Use the play forward and play backward buttons, and the menu knob to scrub through the Cine. A long press on the forward and reverse buttons will start a fast-forward and fast-reverse playback.

Edit the Cine

Tap the menu knob to further edit and save the Cine to CFast. An action menu appears with more options.

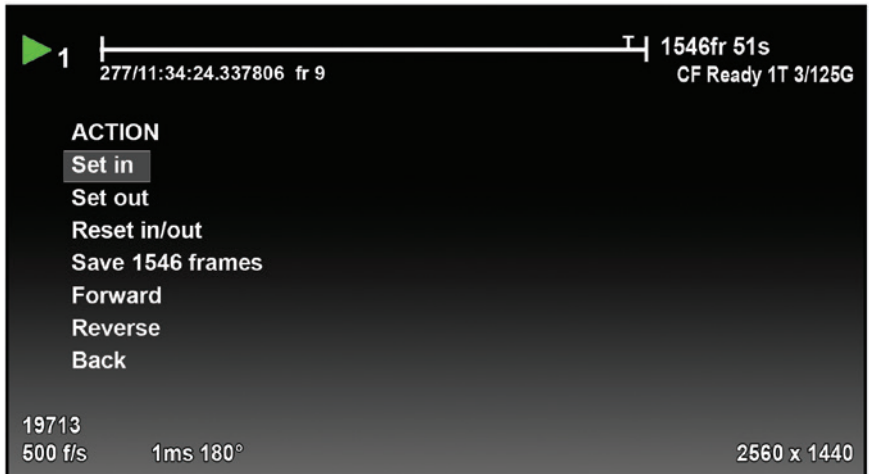

There are a few ways to go through the playback. A preferred way is usually to use the scroll knob to go through the cine.

Set an in-point by selecting “Set in”. This will be the first frame of the cine saved to RAM. Scroll to the last frame you want to save and select “Set out”.

Save the Cine

Now, select “Save” to save the Cine to the CFast 2.0 card. The OSD will report the save progress with a countdown. It is important not to interrupt this saving process, otherwise the card may need to be re-formatted prior to continued use.

Once saved, the RAM can be cleared and the camera can go back into Capture mode. The fastest way to do this is to hold down the trigger button for 4 seconds.

5

Working with CFast 2.0 Cards

Introduction



Important Workflow Notes

Phantom VEO-S camera models are compatible with industry standard CFast 2.0 cards. These solid-state cards are a common form of media for professional video cameras.

Working with CFast 2.0 cards enables footage to be quickly transferred from the camera's RAM to safe, non-volatile storage which can then be later downloaded using Phantom PCC software or a CFast 2.0 reader connected to a PC or Mac. There are several benefits to using these cards:

- Security. Using CFast is a secure way to get the recorded Cine Raw files out of volatile RAM.
- Quality. Files saved to CFast cards are always saved in the Cine Raw format, which maximizes image quality and workflow options.
- Portability. Using a CFast card means there is no need to connect the camera to a PC.

A CFast 2.0 card installed in a Phantom VEO camera can not be used for video playback. Video playback is from camera RAM only. CFast takes can be reviewed over Ethernet, in Phantom PCC software.

VEO cameras only support Loop mode recording. Images must be captured to RAM first, then reviewed and saved to the CFast card. The transfer rate from RAM to the card is approximately 90 MB/second.

VEO cameras do not support Run/Stop mode (longer record times at lower frame rates) like cameras with CineMag compatibility.

Choosing a card

CFast 2.0 Card Format

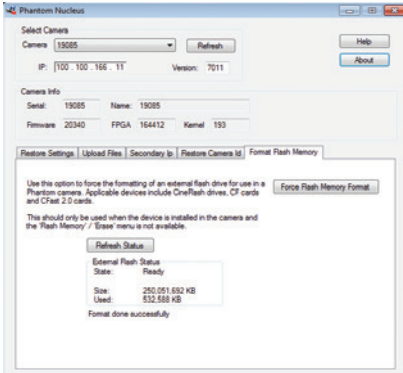

Installing and Removing a CFast 2.0 card

The only requirement is that the card is specified as “CFast 2.0”. Vision Research has verified various Angelbird and Lexar branded cards, however any CFast 2.0 is expected to work.

VEO cameras require the card to be formatted with the NTFS file system. The NTFS format allows CFast 2.0 cards to be mounted to a Windows (read/write) or Mac (read-only) without the need for special drivers.

CFast cards purchased from Vision Research will be pre-formatted, however it is likely that cards purchased elsewhere will have a different file system. When cards are in a different file system, the card will show a “CF Error” on the on-screen display, and PCC software will not recognize that there is a card installed.

There are three ways to format a CFast 2.0 card:

1. Installed in the camera, using the on-camera control menu. The camera will count down 3-2-1 and then it will be ready. It takes a few seconds.
2. Installed in the camera, using the Nucleus utility in Phantom PCC (pictured at left). The Format Flash Memory tab and “Force Flash Memory Format” function should be selected.
3. Installed in a CFast 2.0 reader (typically USB or Thunderbolt) connected to a Mac or Windows PC, using the disk format utility. Choose NTFS while doing the format.



Formatting erases all files on the card. Ensure takes are saved to a secure location before using any of the format options.

Insert the card into the camera’s CFast card slot on the rear of VEO-S camera models. The card will be available immediately, as long as it is formatted NTFS as described above.

To remove the card, press the plastic lever under the card slot. Wait approximately 10 seconds before installing another card. During this time “CF Disconnecting” will appear on the on-screen display.

Saving to and from a CFast 2.0 card

First, a Cine must be saved to the RAM of the camera: Start in capture mode, trigger the camera once the event happens (depending on the post-trigger position)

Review the Cine in RAM, set in and out points as described in the previous section, and save to the CFast 2.0 card. Once the card is full, there are two ways to save the files.

1. Drag and drop the files using a CFast 2.0 card reader - these are typically available with USB or Thunderbolt interfaces (or both).
2. Use PCC software to save the files from the card. The following goes over the PCC procedure:

From the 'Play' tab in PCC, select the cine you want to save from the 'Cine:' pull-down menu. You will see all clips in the RAM as well as the CFast in this list. Once you've selected a clip, you can mark an in and out point if desired by clicking the '[' and ']' buttons respectively.

Then click the green 'Save Cine...' button. In the 'Save Cine' dialog box, choose 'Cine Raw' as the file format, navigate to the folder where you wish to save the clip and click 'Save.'

In the Play Tab, click the triangle to the right of the 'Save Cine...' button, and from the popup menu select 'Save All Flash Cines To File.'

In the subsequent save dialog window, navigate to the folder where you wish to save the clips, and select the 'Cine Raw' file format. Choose a name for the group of Cine files and click the 'Save' button. Each Cine's file name will start with the name you choose, and end with the cine number.

In the Play Tab, click the triangle to the right of the 'Save Cine...' button, and from the popup menu select 'Select&Save Cines to File.'

Saving an Individual Cine

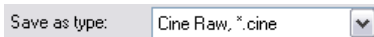

Saving ALL Cine files

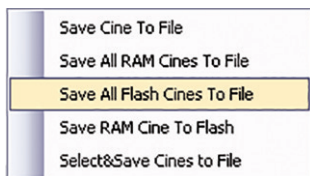

Saving Selected Cine files



"_Flashcine#" will be appended to the file name of all batch-saved clips, where "#" represents the number of each take.

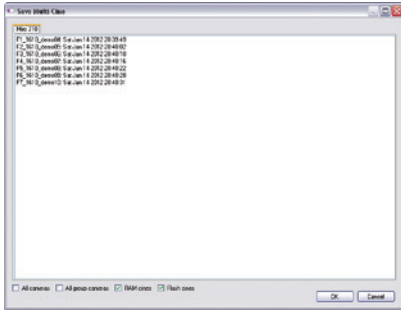

Selecting a file format (choose Cine Raw)

Erasing a CFast 2.0 card

In the popup window, select the cines you wish to save. Use the shift key to select a range of clips, or the control key to add individual clips.

When you've selected the cines you want to save, click "OK." In the subsequent save dialog, choose the destination folder and select the Cine Raw file format. Choose a name for the clips and click the "Save" button.

Vision Research recommends that you save the clips from a CFast card as Cine Raw files, even though it is possible to save them in a number of file formats. Cine Raw files not only preserve all the metadata of the clip (such as frame rate, shutter speed, timestamps, etc), it is the fastest and best-quality format. Cine Raw files can easily be converted to other formats later.

The 10-bit 'Packed' format is the default when saving Cine Raw files. This results in smaller, more manageable files than the 12-bit 'unpacked' format, and with no quality loss. If you are using 3rd party post production software to read the Cine Raw files, please ensure they are compatible with this 'packed' format. To save the Cine Raw in an unpacked format, simply un-check the 'Packed' box prior to saving.

A CFast 2.0 card can be erased using the CF Format function of the VEO menu system, or in Phantom PCC software. PCC will let you delete individual cines, otherwise the format will always erase all Cines.

In PCC software, navigate to the "Live>Flash Memory" menu and click the "Erase" button. Delete individual clips, delete all, or Format the card. Confirm that you wish to delete all clips.

Once complete, all data on the CFast card will be erased, and the card will be ready for recording again right away.

6

Phantom PCC Software



The latest version of Phantom PCC software can always be downloaded from the Vision Research website: www.phantomhighspeed.com/pcc

Pre-Installation

Phantom control software is certified to operate with the following Microsoft Windows operating systems: Windows 7 Pro, Windows 8.1 and 10.

The computer and camera must be associated with the same sub-network to communicate with one another. Please refer to **Chapter 3: Network Settings** in this manual for instructions how to set the Gb Ethernet and/ or 10Gb Ethernet network adapters to communicate with Phantom cameras.

When multiple computers or network cards are used together, each port requires a unique IP address, for example, 100.100.100.1 (255.255.0.0), 100.100.100.2 (255.255.0.0), and so on.

PCC Application Overview

Phantom Camera Control (PCC) software is built around a multi-layered work area that includes the following work areas:

Toolbar

Provides quick access to the most frequently used functions. Position the mouse over a button and wait for a second to display a text box describing what it is.

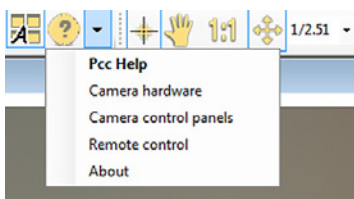

Note the 'Help' section. This provides valuable reference information on the software, including extensive documentation.

Control Tabs

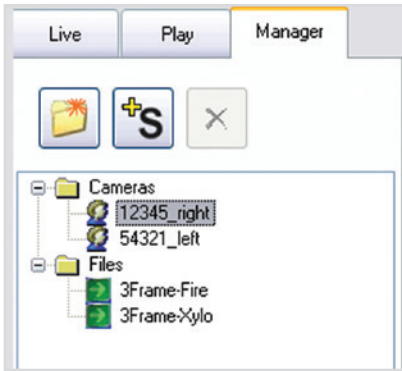

PVP (Phantom Video Player) Application Overview

The main window of PCC is divided into three tabs: Live, Play and Manager.

When first opened, the 'Manager' tab is selected. This is where connected cameras are displayed, selected for use, and renamed. It is also used to manage saved Cine files.

To rename, highlight then click the name of a camera. This can be useful when working with multiple cameras.

All camera control and setting of shooting parameters (frame rate, shutter, etc.) is performed in the 'Live' tab.

The 'Play' tab is used to review, edit, and save Cine files, (either from the camera or from files on the local hard drive).

PVP can be launched directly from the desktop, or by clicking the 'Video Out' toolbar button in PCC.



PVP controls only the camera's video outputs (HD-SDI and HDMI) as connected to a compatible monitor.

It provides streamlined control for playback and basic capture, trigger and save commands.

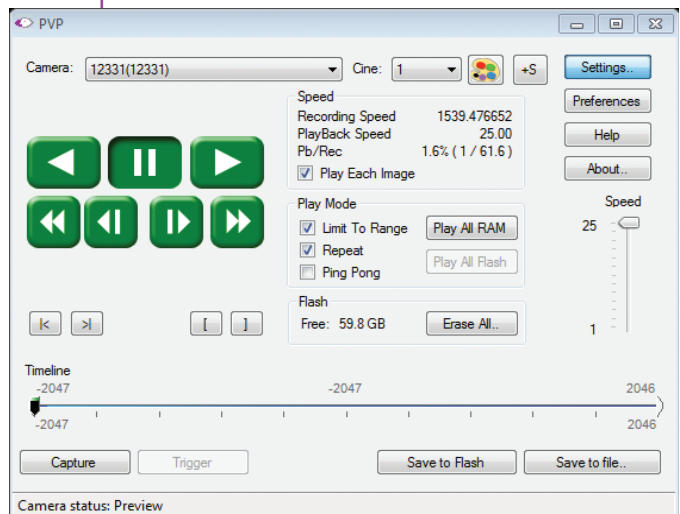

pcc and pvp

Camera Control via PCC



PVP provides the ability to view, capture, review, edit, and/or save a Cine recorded into the camera's RAM to a hard drive, or installed CFast card. PVP is extremely effective when used with high-resolution cameras since most computers are not powerful enough to view the live or captured raw files smoothly over Ethernet.

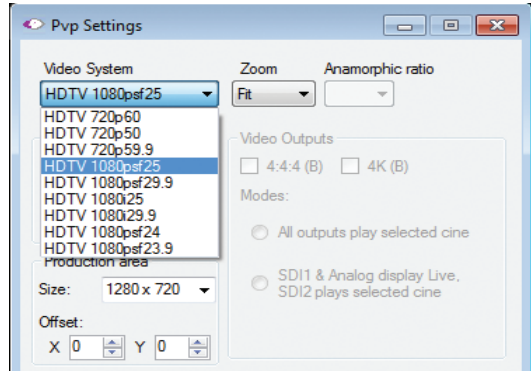

The camera's video mode and display settings are also set through PVP. The best video system for the camera or project will vary based on the country you are in, what kind of video monitor used, and the required display resolution.

All available video systems for the connected camera can be found in the 'Settings' menu of PVP along with production area and other video overlay controls.

The first time PCC is launched it is important to set up user preferences. PCC provides the ability to select various units for specific camera parameters by clicking the 'Preference' button at the bottom Manager tab.

Units can be set to commonly used values ('Presets') or they can be customized using the pull-down selections. First time users should use one of the three 'Presets'.

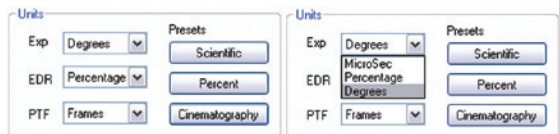

The 'Exp' unit is probably the most important unit to be set. It specifies what unit to use for displaying the exposure time. This can be displayed in degrees, microseconds or percentage. 360 degrees = 100% = the maximum exposure time. The other units to set are PTF (Post Trigger Frames) and EDR which are covered later in this section.

Selecting a Camera

Double-click the camera(s) to be controlled listed in the 'Manager' tab, or select the camera(s) from the 'Camera' pull-down list in the 'Live' tab.

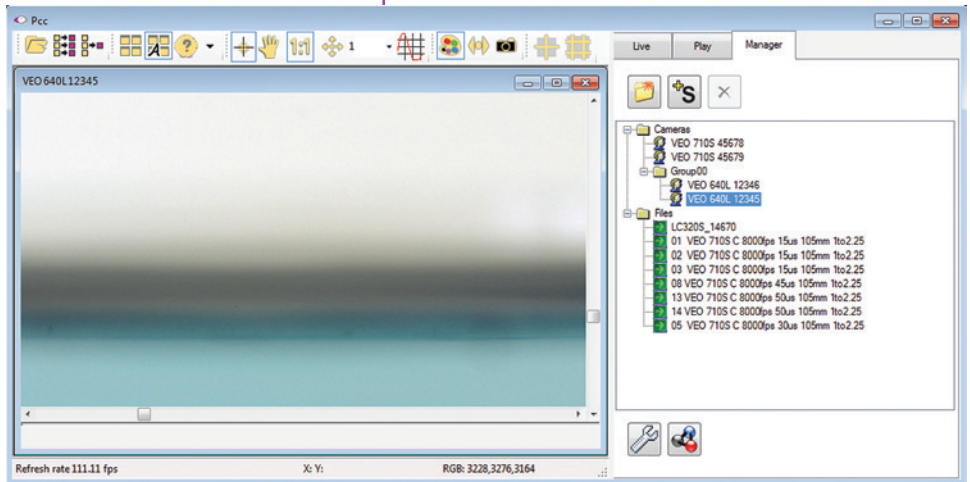

Once a camera is selected a 'Preview' panel will display to the left of the control tabs showing the current image being captured by the camera. This image may differ slightly to that of the image being output over the camera's 3G HD-SDI port due to display differences in the video monitor and computer screens.

Image Processing



Image Tools provides extensive controls over the look of the image, from color and contrast settings, to image orientation and crop settings. The menu is accessed by clicking on the 'Image Tools' toolbar button (the one that looks like an artist's palette).

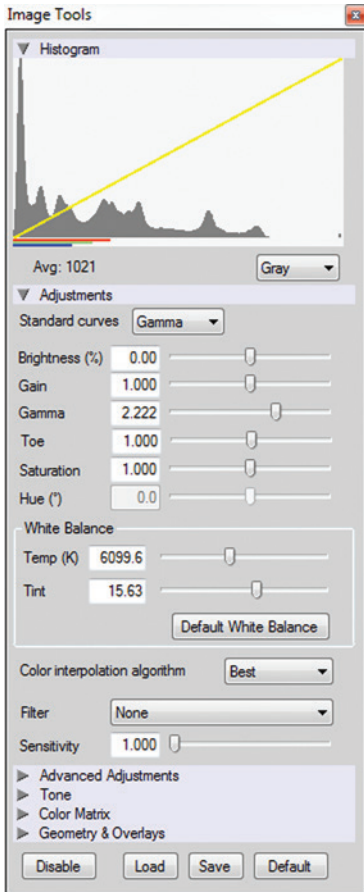

The top of the 'Image Tools' window displays a 'Histogram'. This is a graphic representation of the pixel brightness levels of the displayed image. The left represents black, the right represents white and the height represents the proportionate number of pixels at that particular value. Unlike a waveform, the histogram's shape is not representative of the content - it is simply an averaging of the brightness values.

Below the histogram are controls which change image settings of the live images, recorded images and the video output of the camera.

Some of the variables include; brightness, gain, gamma, saturation, hue, white balance adjustments (Temp (K) and Tint), individual red, green and blue pedestal, gain and gamma values, tone control, and more.

At the bottom of the window is a 'Default' button that restores all parameters except white balance, tone, and color matrix to their default values.

The 'Default White Balance' button restores white balance to the factory defaults on color cameras.

The Tone 'Reset' button restores the image tone to the default values, and the Color Matrix 'Restore' button return the color matrix values to their default values.



Changes made here only affect the meta data of the Cine raw file. They are applied in software, but not "baked in." If you are saving to a different format or recording the video output ensure everything is set to values that produce the image you wish to record.



The 'Zoom Actual Size' toolbar button resizes the images being displayed in the Preview/Playback panel to their actual size.



The 'Zoom Fit' toolbar button resizes the images to fit panel. Images can also be zoomed to a specific magnification ratio by selecting a number from the pull-down list to right of the Zoom Fit button.

Automatic White Balance

Performing a White Balance should be the first step in color adjustment (White Balance not applicable to monochrome cameras).

Right click on an area that resembles white in the image in the 'Preview' or Playback' panel, then click on the 'White Balance' pop-up window. It is not necessary to fill the frame with white – a small target can be used.

It is recommended to perform the White Balance after a CSR and on a white or gray object that is not fully saturated.

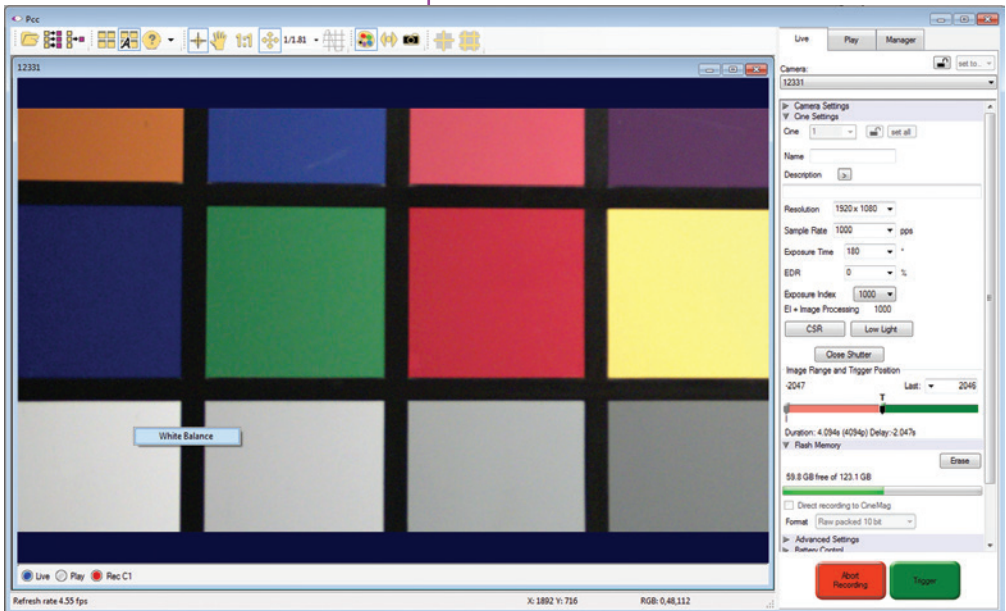

Capture Setup

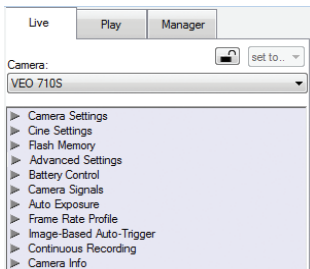

Just below the 'Camera' selector in the 'Live' tab are a series of expandable headers, which contain groups of related camera settings.



This manual covers the most commonly used settings, see the 'PCC Help' file for details of other settings.

Camera Settings & Cine Settings

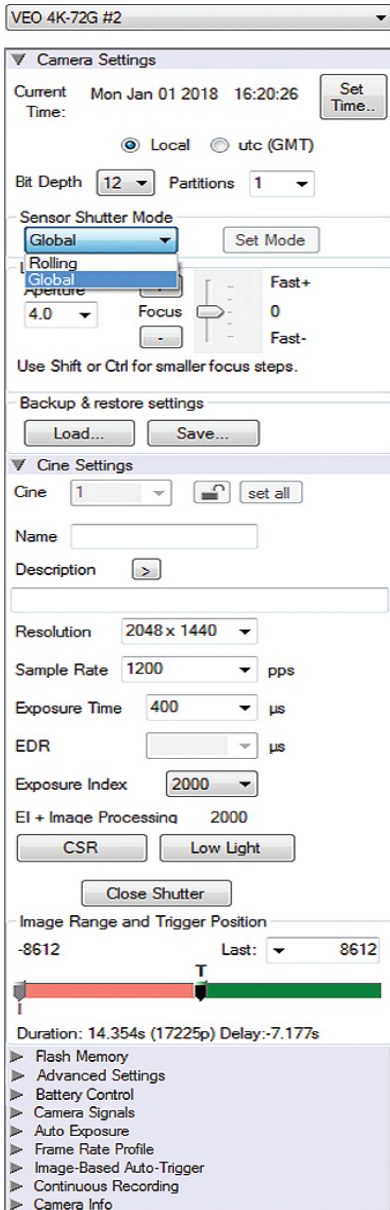

Set Time: Synchronizes the time stamps embedded in the recorded image data to the computer's clock.

Bit Depth: VEO cameras operate in 12-bit mode only.

Shutter Mode: For VEO4K models only. Switch the camera between operating with a Global or Rolling Shutter. Once set, click 'OK' to confirm. See FAQ on this topic for more information.

Partitions: Select the number of desired partitions (evenly divided memory segments) from the 'Partitions' pull-down menu. For basic camera setups, this should be set to one.

Lens Control: Available for Canon EF lenses only, for control of aperture and focus.

Backup & Restore: Allows for user and factory settings to be saved and recalled from the camera's memory.

Resolution: Set the camera's acquisition resolution. There are several options in the pull-down menu, alternatively type in a value and the closest valid resolution will be set.

Sample Rate: Set the acquisition frame rate in frames-per-second (FPS).

Exposure Time (shutter): Set the exposure time in degrees, microseconds, or percentage (this depends on how the PCC preferences are set).

EDR (Extreme Dynamic Range): Set a secondary exposure time to pixels that may become fully saturated or overexposed. This is valuable for monochrome cameras, but be careful with color cameras as a color cast will occur on the areas of the image which EDR is applied. VEO4K models are not compatible with EDR.

Exposure Index: Set the exposure index (Effective ISO) of the image, by loading preset tone curves. Adjusting gamma, gain and other settings will contribute to the overall EI value, and this combined value is what should be used to determine lighting.

CSR (Current Session Reference): Closes the camera's internal shutter and resets the black point of every pixel for optimal image quality.

Key Advanced Settings

Start/End of recording actions

- Auto Black Reference
- Auto save to CineMag/built-in Flash
- Auto save to CineFlash/CardFlash
filename:
- Auto play Video Out times

Range: FullCine
First Last

- Restart Recording

External Sync

Sync Imaging: ▼

Master camera serial (0=none)

Frame Delay μ s

Image Range and Trigger Position: The slider represents the memory buffer, with the 'Duration' indicated in seconds and the total number of frames available.

The trigger position is indicated in the 'Last' pull-down menu and as the 'T' slider along the timeline. The trigger position is exactly when the trigger signal will be detected in the Cine.

The first of these key features is the option to enable the 'Start/End of recording actions' to be performed automatically at the beginning or end of a shot. The most common ones are:

- 'Auto save to CineFlash/CardFlash' this feature saves a user-specified portion of a clip to the CFast card immediately after recording.
- 'Auto play Video Out' begins playback after recording. The range marked under 'Auto play Video Out' affects both playback and saving to the CFast 2.0 card.
- 'Restart Recording,' when enabled, automatically restarts the recording process after the 'Auto' actions have been performed.



When 'Restart Recording' is enabled PCC does not provide any user confirmation before the clip is erased from RAM and starts recording again.

This feature should be used with care!

'External Sync' instructs the camera to utilize one of the following three frame sync clock sources:

- Internal - The camera uses its internal crystal oscillator to drive the camera's frame rate.
- External - should be selected when an externally supplied frame sync clock pulse is supplied to drive the frame rate. This can be used to synchronize two cameras together via F-Sync.

Flash Memory

Recording a Cine

Triggering the Camera

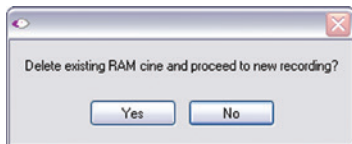

- IRIG - should be selected when an IRIG-B signal is supplied to drive the camera's frame rate. When using IRIG, frame rate can only be set in multiples of 100.
- LockToVideo - Frame rate is driven by the camera's current video rate. FPS will jump to the closest multiple of the current video rate (23.98, 24, 25, 29.97 or 30).

Displays the amount of 'Free' space and size (in Giga-bytes) of an installed CFast card. Direct recording is not an option for VEO cameras. By clicking 'Erase' a secondary menu pops up which allows you to delete individual files or format the card.

To begin recording to the camera's RAM click the red 'Capture' button.



The red 'Capture' button changes to 'Abort Recording' and the green 'Trigger' button is enabled when the camera is recording. The Abort Recording button instructs the camera to stop recording, leaving the camera's RAM empty.



Selecting the 'Trigger' button instructs the camera to immediately stop recording when the 'Trigger Position' is set to zero. If a value greater than zero is set, the camera will continue to record 'post-trigger' frames until the user-specified value is met.



If a clip exists in the camera's memory, you will be asked if you are sure you wish to delete it before continuing. If yes, click 'Delete cine(s) and start new recording'.



For a precise trigger timing use the trigger button on the camera body or an external switch connected to the trigger input.

Reviewing a Cine

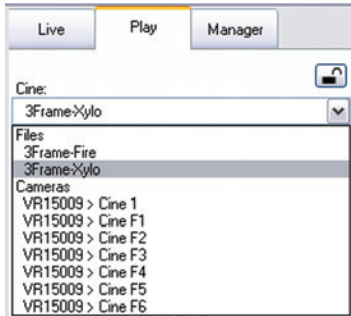

Once the camera has completed recording a Cine in the camera's RAM it can be reviewed by selecting it from the 'Cine' pull-down selection list in the PCC 'Play' tab.



A previously saved Cine stored on the computer's hard drive can be opened using the 'Open File' toolbar button (This also places the file under the 'Cines' group folder in the Manager tab).

Playback options can be changed via the 'Play Speed & Options' and the Cines' metadata can be viewed in the 'Frame Info' and 'Cine Info' sections.

Use the 'Video Control' buttons to review the cine.

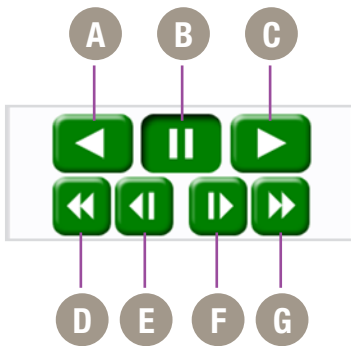

- A** Reverse Play
- B** Pause
- C** Play
- D** Fast Reverse
- E** Reverse 1-Frame
- F** Advance 1-Frame
- G** Fast Forward

Performing a Quick Search Through a Cine



Quickly search through cine file to find the points of interest:

'Scroll' (scrub) through the clip using the 'Image Location' slider or click anywhere on the timeline to jump to points in the cine quickly.

'Jump' to the trigger frame by clicking on the 'T' button, or jump to specific frames by entering the frame number into the jump "#" data entry field, then hit the enter key.

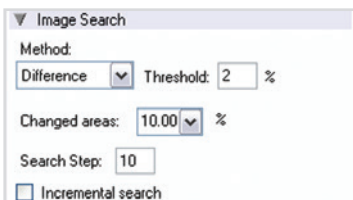

'Image Search'. The goal is to search or find an image change in the recording, based on the difference between image content. Right-Click on the 'Play' button to begin the image search. Besides image content changes, Image Search can also look for images that are tagged as 'Event' images.

Editing a Cine

Using the following 'Video Control' buttons locate the first image of the cine to be saved and click the 'Mark-In'  button.

Locate the last image of the cine to be saved and click the 'Mark-Out'  button.

Click 'Play, Speed, & Options' and enable (check) 'Limit to Range'.

Under the 'Video Control' buttons click the 'Jump to Start'  button, then review the edited cine.

Saving a Cine

Click the 'Save Cine...' button to save the edited cine to the computer's hard drive.

If you wish to save the clip to a CFast 2.0 card, click the down-arrow to the right of the 'Save Cine...' button and select 'Save RAM Cine to Flash'.

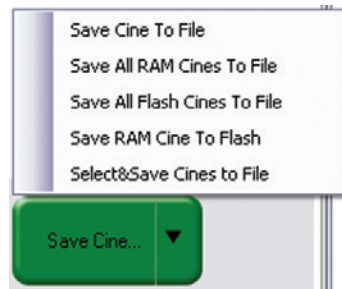

Working with Cine files

The images recorded on the camera's RAM or CFast card are stored in a Vision Research proprietary RAW (uncompressed) file structure called a 'Cine' file.

These Cine files can be converted to industry standard formats (ProRes, H264, DPX, DNG, TIFF, JPEG, and more) with PCC software provided by Vision Research.

Phantom PCC and PVP software are only compatible with Windows operating systems, however there are third party solutions available for working with Phantom cameras in Mac OSX.

Glue Tools™ offers the most versatile solution, called the 'Phantom Cine Toolkit'. The Toolkit allows for cine raw files to be viewed on the Mac in a quicktime .mov wrapper. This enables many popular editing programs to work with cine files, such as Final Cut Pro and Avid Media Composer.

Compatibility with Video Editing Programs

Several popular video editing programs, such as DaVinci Resolve and Adobe Premiere, have incorporated the Phantom Cine Raw file format into their software. This means Cine files do not have to be converted and no additional software is required.

Please test the footage with the program you choose before committing, as updates to the program or Cine file format can sometimes break compatibility. For this reason, it is important to know how to properly convert Cine Raw files using PCC.

Converting Cine Raw Files

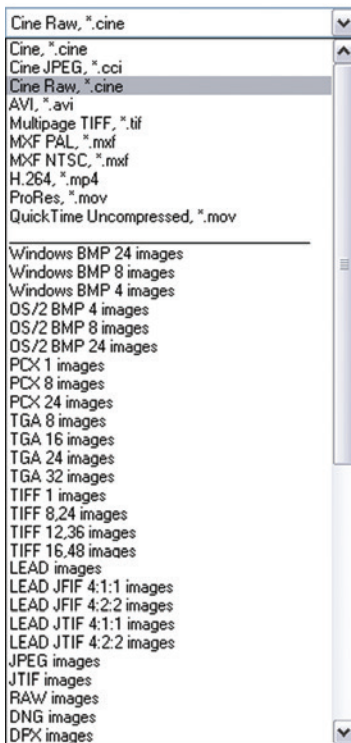

Single cine files can be converted by selecting the desired format from the 'Save as Type' selection list in the 'Save Cine' dialogue window.

The file formats above the separator line in the 'Save as Type' selection list are 'movie-like' formats (meaning the entire clip will be saved as a single file) while the formats below the line are image formats (meaning each frame of cine will be saved as a sequence of images).



Re-saving a clip in the 'Cine RAW' format can be useful for creating sub-clips with no loss in image quality or metadata.

To convert a cine to a 'movie-like' format select the desired format from the list, navigate to the destination folder, assign a file name to the clip and save.

Some valuable parameters can be found in the 'advanced settings' window, such as the particular codec. In the case of ProRes, the default is 4:2:2 HQ, however other options are available.

Other formats, like .avi and .mp4 allow the compression ratio to be entered. The lowest compression (highest quality) is the default.



Ensure all image adjustments have been applied prior to initiating the conversion process. All metadata will be embedded into the converted images.

Converting to a Series or Stack of Images

To convert a cine clip into a sequence of images (frames) you must add one of the following annotations to the end of the file name: '!n' or '+n' (where n is a number between 1 to 8, corresponding to the Cine's frame count). If a cine has up to 999 frames, the number 3 can be used. If it has 9999 frames then 4 can be used. This will assign the sequential frame numbers to the file name for each new image.

Example: image_!5.tif

The '!' annotator instructs the software to append the cine's image number (relative to the trigger point) to the file name. If the first frame in the clip is - 100, then the first converted frame will have the name: image_-00100.tif.

The '+' annotator adds frame numbers starting from 1.

Example: image_+5.tif

This will cause the first converted frame to have the name: image_00001.tif

Batch Convert



The 'Batch Convert Files' toolbar button can be used to convert multiple saved cine files into any one of the supported file formats. Use the shift and/or control keys to select the cine files you wish to convert in the 'Open Cine' dialogue window, then click the 'Open' button.

Navigate to the destination folder and select the file format. The 'File Name' will depend on the type of file format you are converting to.

If you are converting the cine file into a 'movie-like' formats leave the file name as 'All selected file.' The software automatically assigns the original file name to the converted file.

If converting each Cine into a sequence of images, then the '+' or '!' annotators must be used, followed by the specified number (example: *image_+5*)

PCC creates a separate folder for each file, assigns the original file name and appends the appropriate image number and extension to each image.

Once the 'Convert' button is clicked a progress window appears for the duration of the conversion process.

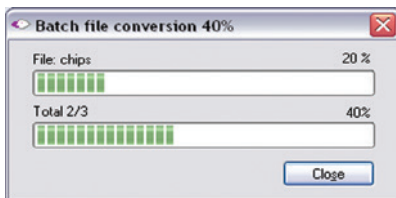



7

Programmable I/O Signal Architecture

“Programmable” vs “Assignable”

Phantom cameras have long employed the use of Auxiliary ports where one BNC port, whether on the camera body, capture cable or break-out box, can be assigned to one of a few different signals. This has been necessary due to an increasing number of signals and a limited amount of physical space on the camera and pins on the capture connector.

On those cameras the port is labeled “Aux” and the ‘Camera Signals’ menu in PCC is used to select the signal. This feature can be referred to as “Assignable” I/O.

With the introduction of the Phantom VEO the camera incorporates a pulse processor, which contributes to a new powerful feature called “Programmable I/O”. In addition to assigning different signals, now the signal characteristics can be modified to interface with external devices not before possible.

In most cases the signal polarity, filter time, delay, pulse width and edge (rising vs falling) can be set. Setting these characteristics is referred to as “pulse processor control”.

Phantom VEO and Programmable I/O

Programmable I/O ports can be identified on the camera body with a ‘P’. Both models have a fixed trigger and Timecode-in port, and then VEO S-models have four Programmable I/O ports (P3, P4, P5 and P6) and L-models have two (P3 and P5)

Each port is to be identified in the PCC ‘Camera Signals’ menu by using the port number. Each Programmable I/O signal has a default which will be set after a factory reset or by using the “signal defaults” function in PCC.

VEO Signals with Default Assignments

	VEO L-models	VEO S-models
Port 1	Trigger (fixed)	Trigger (fixed)
Port 2	Timecode-in (fixed)	Timecode-in (fixed)
Port 3 (P3)	Prog I/O - Default: F-Sync	Prog I/O - Default: Strobe
Port 4 (P4)	N/A	Prog I/O - Default: F-Sync
Port 5 (P5)	Prog I/O - Default: Strobe	Prog I/O - Default: Ready
Port 6 (P6)	N/A	Prog I/O - Default: Timecode out
Range Data	None	Yes, dedicated Fischer port

PCC interface

Camera Signals

1 Trigger
Falling Edge
Filter: 32 µs Delay: 0 µs

2 TC In
Fixed Port

Programmable I/O: Default All

P3 Strobe
Width: 0 µs
Filter: 0 µs Delay: 0 µs

P4 F-Sync
Width: 0 µs
Filter: 0 µs Delay: 0 µs

P5 Ready
Width: 0 µs
Filter: 0 µs Delay: 0 µs

P6 TC Out
Width: 0 µs
Filter: 0 µs Delay: 0 µs

Beginning with Phantom PCC 2.8 the Camera Signals menu, located in the Live Tab, provides access to and control over these Programmable I/O signals. All listed signals are not necessarily active with VEO, including Runstop and Mstrobe.

P5 Ready
Ready
Strobe
F-Sync
TC Out
Mstrobe
Auto Trigger
Sw Trigger
Recording
Event In
Memory Gate In
Pre-trigger In
Runstop In
Core Aux Trigger In
Core Event
Core Memory Gate
Core F-Sync
Core Pre-trigger
Core Runstop
Core Aux Trigger
Core Trigger

A summary of the current signal settings is found under the pull-down associated with each port. By clicking "Default All" PCC will re-assign the factory-assigned defaults for the Programmable I/O signals.

Pulse Processor Control

After selecting the signal assignment, further configuration is possible by clicking the gear symbol next to each port. The Pulse Control menu is opened, as shown below.

A graphic representation of the signal behavior is also displayed, however this is **not to scale** and should just be used as a reference. Use of this feature requires an oscilloscope to truly visualize the signals and the subsequent changes with each adjustment.

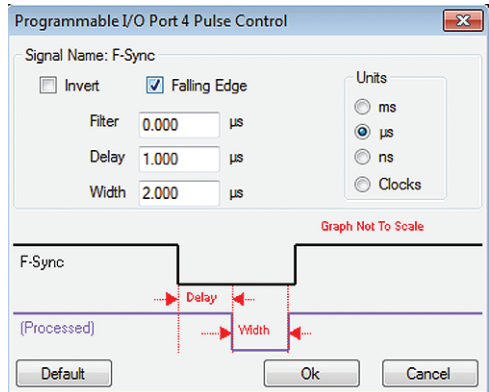
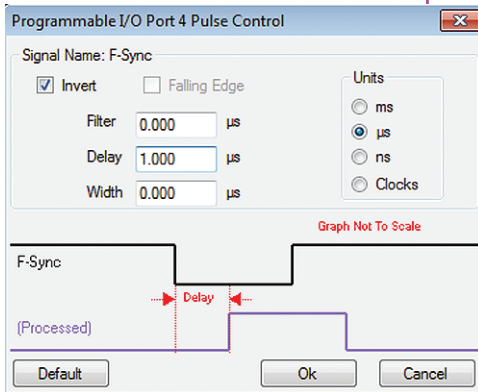

Summary of Pulse Processor Settings

***Input:** When a signal is generated by the camera it serves as an input to the “pulse processor”, so in this context the term ‘input’ does not represent an externally generated signal.

Invert: Inverts the signal at the output of the pulse processor.

Falling: Selects ‘Falling Edge’ mode for the pulse processor. This mode is only relevant if the ‘Width’ is also specified. When the ‘Falling’ token is present together with ‘Width’, the pulse processor will generate a negative pulse, triggered from the negative edge of the input signal.

Delay: Delays the output pulse by the specified time in ms, μs, ns or camera clock multiples. If the ‘Width’ token is not present, both edges of the signal are delayed by the same amount. If present, the delay is measured from the rising edge of the **input*** signal unless the ‘Falling’ token is present, in which case the delay is measured from the falling edge of the ‘input’. The delay time is specified in microseconds (as a floating point number), and is internally converted and rounded to pixel clock units.

Pulse Processor Settings (cntd.)

Width (Pulse Width): When a 'Width' token is present, a defined-length pulse is generated, which starts after the specified 'Delay', after the active edge of the 'input' signal. The length of the pulse is specified in microseconds (as a floating point number) and internally converted to pixel clock units. The maximum pulse width is at least 10 seconds. However, if the period of the 'input' signal is lower than the selected width, the latter is dynamically clamped to the signal period. The minimum pulse width is one pixel clock.

Filter (Filter Time): When a filter token is present, the 'input' of the pulse processor is filtered through an edge filter of the specified time. The time of the filter can be between 0 and 1 second. In order for the output of the filter to be asserted, the 'input' signal must be continuously asserted for the specified duration. In order for the output of the filter to be de-asserted, the 'input' signal must be continuously de-asserted for the same duration. The edges of the 'input' are thus delayed by the specified filter time (for a 'clean' input pulse). Filtering is applied before and independently of the delay and duration. The filter time is specified in microseconds (as a floating point number), and is internally converted and rounded to pixel clock units.

Pixel Clock

The period of the pixel clock is the basic time interval for all camera timing.

Please note that pulse processors can sometimes generate pulses that are too short for the output drivers to switch properly, and as such the processed signal should be verified with an oscilloscope before use.

Programmable Signals and Descriptions

Ready: An isolated open collector output with 1k pull-up signal (active high). Ready is asserted when the camera goes into capture mode and is de-asserted either when the Cine is triggered, or when the Cine recording is completed. Ready changes synchronously with frame capture (at the end of each exposure), so in external sync mode it will not change until F-Sync pulses are received.

Strobe: An isolated open collector output signal, with 1k pull-up. When asserted (low) Strobe indicates that the camera integrates (the electronic shutter is open). Strobe is low for the duration of the exposure.

Programmable Signals and Descriptions (cntd.)



Note: All descriptions are the signal's default state prior to processing.

F-Sync: Is the only signal which can be set as an output or input. By default it is output (sync-internal). Output signal is a frame sync pulse from the camera's frame rate generator. A short (few hundred ns depending on camera model) negative pulse, with the falling edge used as timing reference. Input signal is active on falling edge (default state is high).

TC Out: A positive polarity time code signal. Normally an unmodulated (dc-shifted) IRIG-B (at RS-232 levels), which follows the internal time base of the camera. It is recommended not to process the TC-Out, since a processed signal may no longer represent a standard or accurate time code.

Auto Trigger: Used to output a hardware trigger signal or pulse with the duration.

Software Trigger: An active high output signal (pulse) generated as a result of the trigger protocol command.

Recording: An active high output signal. When active, indicates the camera is recording into a RAM partition.

Event In: If the input is sampled low at the end of an exposure, an 'E' (Event) bit in the frame's time stamp is set.

Memory Gate In: If the input is sampled low at the end of an exposure, the corresponding frame is skipped from storage to RAM.

Pre-trigger: An active low input (default high) signal. Keeping this signal low for enough time (10-500ms, or until the 'Ready' signal goes high) will make the camera start recording if it has an available RAM partition.

Aux Trigger: An input signal active on rising edge (default high). This is an alternative trigger input that can be processed through the programmable port pulse processors and assigned to different ports.

core signals

Programmable Signals and Descriptions: The Core Signals

Core signals are copies of externally generated signals, routed through the camera and output to assigned ports. Core signals can be pulse-processed before being output.

The current list of signals is:

Core Event: Feedback output from the Event In signal. The feedback is taken after any pulse processor for the input.

Core Memory Gate: Feedback output from the Memory Gate In signal. The feedback is taken after any pulse processor for the input.

Core Frame Sync: Feedback output from the F-Sync In input. The feedback is taken after any pulse processor for the input, but before the delay element.

Core Pretrigger: Feedback output from the Pre-Trigger signal. The feedback is taken after any pulse processor for the input.

Core Auxtrigger: Feedback output from the Aux Trigger In signal. The feedback is taken after any pulse processor for the input.

Core Trigger: Feedback output from the main Trigger input. The feedback is taken before the trigger signal is affected by the trigger polarity, filter or delay settings. “Core Trigger” can be used like a “Trigger Out” signal.

8

Measurements

Introduction

Included in PCC software is a set of 2D motion analysis tools which go a step beyond the visual when it comes to providing valuable data about the subject. Analysts can perform timing, position, distance, velocity, angle and angular speed measurements as well as track multiple points to compute and graph in their XY-coordinates, speed or acceleration. The interface can also harmonize this measured data with images.

This section reviews various PCC measurement capabilities. Further documentation, including Step-by-Step procedures can be found in the PCC help documentation available within the software.

Units of Measurement

Units of Measurement specify the computing and reporting unit for distance, speed, acceleration, angle and angular speed measurements. Establishing a measurement scale is an important first step to using the measurement functions.

Define the Measurement Units in the Preferences menu, accessible by clicking the wrench icon from the Manager tab.

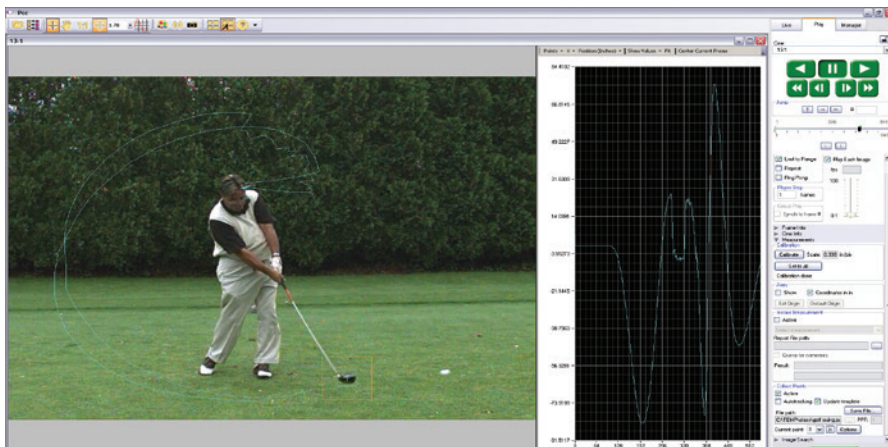

PCC display automatically tracks golf club head to calculate swing speed, path and acceleration.

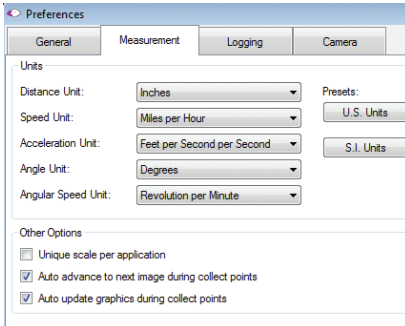

Measurement Tab

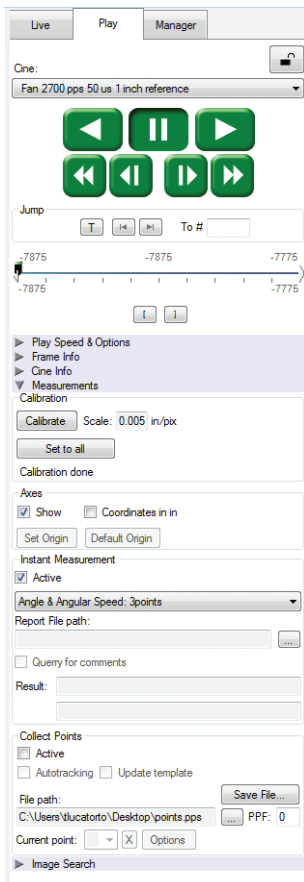

“Other options” in Measurement Preferences:

Unique Scale per Application: When enabled the same scale will be applied to all subsequently opened Cines.

Auto Advance to Next Image during Collect Points: the Cine advances to the next image automatically once all the collect points have been manually specified on the displayed image. This option should be disabled (unchecked) if auto tracking points is to be used.

Auto Update Graphics During Collect Points: A graphical display of the tracked points will overlay the images during the collect point process.

PCC's measurement functions are found in the Play tab and will work with saved files (Cine Raw or converted files) or directly from the camera's RAM playback.

To define a measurement scale, the first step is to use the 'Calibrate' function in the image with a known scale, then specify that scale size. Once created all measurements are computed and displayed using the scale unit.

Coordinate measurements are calculated from an origin point pixel. By default this is the top-left corner of the image however it can be changed when performing measurements. Each coordinate consists of 2 numbers (x,y) indicating the position of a pixel in the image on the two-dimensional plane from the origin point.

Your choice of origin will be largely dependent on the subject and the type of motion being studied.



The 'Default Origin' and 'Set Origin' buttons will be disabled if any of the 'Instant Measurement' or 'Collect Points' options are active.

Once the origin point is set, activate 'Instant Measurements' and select one of the available options for Distance, Angle and Speed or Angle and Angular Speed.

Instant Measurements

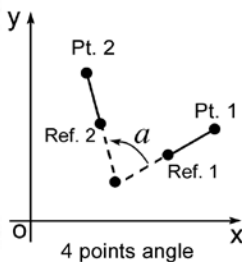
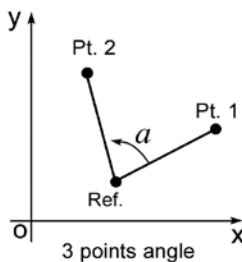
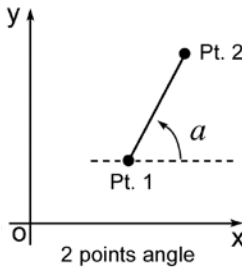
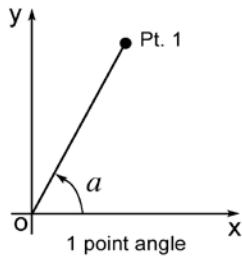

Collect Points

Instant Measurements consists of four unique motion analysis tasks, including:

1. Distance & Angle & Speed: Origin + 1Point. Used to measure the distance and speed of linear motions with respect to a fixed point of origin, the angle formed with respect to the x-axis, or the speed of a rotational motion (computed with respect to the horizontal axis of the picture screen), when only one point is known.
2. Distance & Angle & Speed: 2Points. Used to measure the dimensions of an object or space, the displacement and speed of an object in one image with respect to its new position in any subsequent image, angular speed (computed with respect to a horizontal axis), or the speed of a rotational motion when two points are known.
3. Angle & Angular Speed: 3Points. Used to measure angles when the vertex and the two end points of the angle are visible.
4. Angle & Angular Speed: 4Points. Used when the vertex or the center point of rotation is unknown or lay outside the image area, the angular speed can be found by comparing the position of an object in one image to its position in the next image.

Each of these are calculated by selecting a point (or points) in one frame, then forwarding the video and selecting the same point (or points) in the subsequent frame. Results are posted in the 'Results' area.

All Instant Measurements can be used in conjunction with a Report File or without. With a report file opened, the image number, elapsed time from trigger, unit of measurement, distance, dimension, speed and comments are automatically saved in the file.

Point data (for up to 99 points-per-image) can be collected, tracked within PCC software and imported by third party programs. This feature creates a separate data file for point coordinates, speed and / or acceleration.

Collect Point Data for Tracking

The point data can be collected two ways:

1. Manual Track. Used to track point positions (coordinates) from one image to the next once its starting point is defined.
2. Auto Track. Used to track point positions from one image to the next once its starting point is defined.

Auto Tracking is done during the play of the Cine (step forward, step backward, play forward, play reverse). It is very important that the images be in succession; Auto tracking will self-disable if they are not. To avoid this from occurring 'Play Speed & Options>Play each image' is forced on. It will also disable itself when jumping from the last image to the first. However, the points will remain attached to those areas in the image as they are stored in the user-specified '.ppf' (pictures-per-frame) file. This allows the end-user to reopened Cine and / or pictures-per-frame file to overlay the points, or export the file to a spreadsheet.

Autotracking, Step-by-Step

After the measurement units, calibration scale, and origin point have been defined:

1. Locate the first frame with the points to be tracked.
2. Create a .ppf (picture-per-frame) file by clicking the '...' button near the 'File path' box under 'Collect Points'
3. Navigate to the folder to save the '.ppf' file; enter a name and click on the 'Open' button.
4. Specify the number of points to be collected (tracked) in the 'PPF' field (99 maximum).
5. Enable the 'Active' enable box.
6. Click the center of the point(s) to be tracked. Ideally, the selected points should be a small target or the edge of an object that will be in motion. Do this until all points have been manually specified. If the 'Auto Advance to Next Image During Collect Points' has not been enabled in the 'Preferences>Measurement' tab you will need to advance the file to the next image.

Define Point Parameters

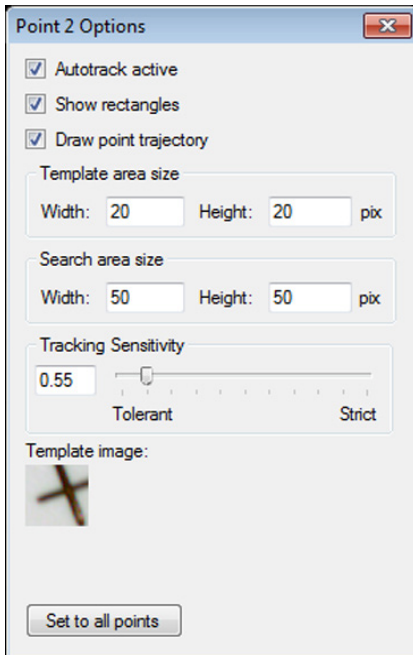

Points used for autotracking can be dedicated markers (crosses, quarter of circles in opposition black-white, white-black) or any objects in image that has something different on two orthogonal directions. The middle of a straight line is not good but an isolated spot, such as the end of a line or a corner are okay.

Once the points are selected, click the 'Current Point/Options' button to further define each point:

Autotrack Active - turns on and off the autotracking of the selected point.

Show Rectangles - displays the 'Target Area' and 'Search Area' rectangles for the point. The region sizes are defined by the 'Template Area Size' and 'Search Area Size' parameters.

Draw Point Trajectory - turns on and off the ability to graph and display the path over the image area.

Template Area Size - defines the width and height (in pixels) of the of the 'Template Image' to search for and track. The center of the 'Template Image' was determined when the point was specified.

Search Area Size - defines how large of an area in relation to the 'Template Area' to search, in the next image, for point matches. A value equal to the 'Template Area Size' indicates that the tracking algorithm should search in a region the same size. Larger values will result in larger search areas, which will take a longer time to search. Typically these values are set to 2-3 times the size of the initial image template.

Tracking Sensitivity - defines the acceptable level of difference between the template and the occurrence in the new image. A strict matching algorithm is used to avoid false matches; however this may lead to more frequent loss of targets during tracking. To compensate for this, you can adjust the 'Tracking Sensitivity' to be more tolerant.

Template Image - displays an image of the point used for tracking.

Set to All Points Button - used to apply the above settings to all currently defined points.

Once point settings are defined, enable 'Autotracking' to turn the feature on. In the event a 'Template Image' (tracking point) can not be tracked or is lost the 'Autotracking' feature will disable itself.

Optionally, enable (check) 'Update Template' to update (change) the 'Template Image' to the image (point) presently marked by the 'Template Area Size' rectangle. Due to rotations, shadows, etc. the point can be lost. If 'Auto update' is enabled, PCC will attempt to restrict the selective disabling of the feature.

Graphics

Optionally, click the 'Graphics' toolbar button to view a chart of the tracked points. This opens a graphical interface (displayed to the right of the Cine image). It is used to display signal acquisition information or position/speed/acceleration and the coordinate X or Y of tracked collect points. The displayed values take into account the global measurement preferences for position/speed/acceleration. Only windows for the type of signals that are present in the .Cine file will be available.

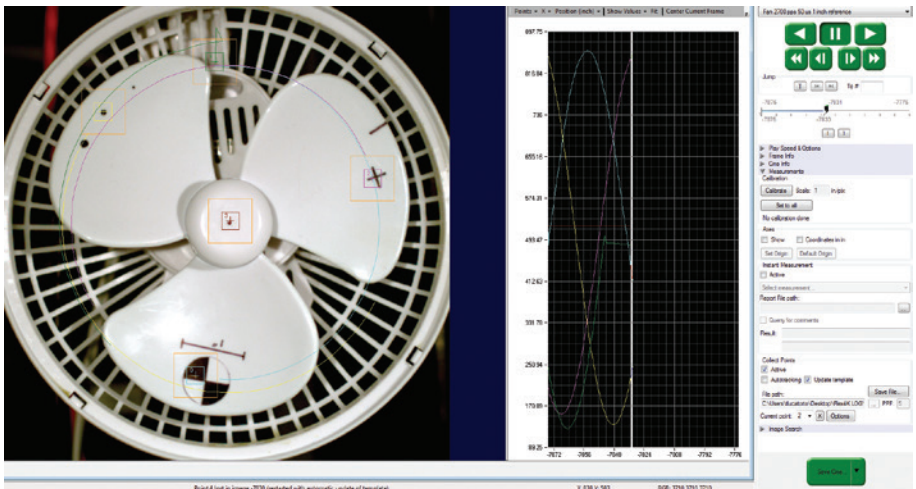

Finishing Steps

1. Deactivate (un-check) Collect Points.
2. Click the 'Save' button to save the completed points and computation files that are required.

9

Accessories

Introduction

Phantom VEO cameras ship with a basic set of all that is needed to get started using the camera, including a power supply, Ethernet cable, SDI cable and PCC software.

Vision Research offers several accessories meant to facilitate the use of the VEO for different applications, as the size and shape of the camera make it particularly well suited for different rigging options.

This section includes a list of some of those key accessories. Check with your sales representative if you do not find what you are looking for here and for pricing info.

Note the VEO is identical on the top, bottom and right side when it comes to mounting points, so these can be attached to any of those surfaces. This allows the same mounting possibilities when using the camera vertically, for example, or in rigs when the camera is to be used upside-down.

Cameo Accessories for Phantom VEO

The Cameo line of accessories from Abel Cine includes a cine-riser, cinema style handle, additional cheese plates, battery solutions and more - designed specifically for the VEO. Basically, everything that is needed to facilitate a production-friendly workflow is included. These items are available stand-alone or as a kit, as pictured here.

Cameo Cine-Style Handle

Cameo handle part # VRI-AB-CAM-VEO-HANDLE
Requires cheese plate (included)



VEO Riser

Riser part # VRI-AB-CAM-VEO-RISER

The Riser is an important accessory that brings the VEO's optical axis to the correct height to work with standard bridgeplates and common 35mm film accessories. The riser includes 15mm Rod support for lightweight accessories like lens supports and smaller matteboxes. Requires cheese plate (included)



Cine Essential Kit for VEO

Kit part # VRI-AB-CAM-VEO-CINE-KIT

The VEO essential kit includes a top handle, riser, rosette bar and 2 cheese plates.



VEObob

The VEObob is part of Abel Cine's CAMEO accessory line. It has an XLR4 power input and routes power to any VEO S-model camera. It provides additional connectivity such as a Remote port and several 12V accessory outputs including those that are found on a Phantom Flex4K.

Battery Solutions

With the addition of a battery mount and an on-camera monitor or viewfinder, a VEO S-model camera becomes a fully portable high speed camera system.

A VEO running with its maximum configuration will consume approximately 70 watts of power.

24V & 12V Power Input

The camera's main power input is 24V (16-28V range). An XLR3 battery cable exists for connecting an off-board 24V battery: Part# VRI-CBL-VEO-BATT-2

VEO-S models include a capture port which offers an alternative 12V power input. When working with batteries in the 12-14.4V range, ensure the battery can supply at least 8 Amps when fully charged.

12V XLR4 Power Input Cable



There are a few different 12V battery mount solutions to choose from, each of which connect to the camera's capture connector.

Part # VRI-CBL-VEO-S-12VBATT-0R2

This short 10-inch XLR4 is meant for connecting 12V battery mounts (with an XLR lead), or connect a 4-pin XLR extension cable for using other 12V power sources.

12V Battery Mounts



Alternatively, choose a battery mount customized to work directly with the VEO.

Part # VRI-VEO-BATT-MNT-AB (Gold mount)

Part # VRI-VEO-BATT-MNT-VLOCK (V-Lock mount)

These mounts work with one of the Cameo cheese plates, which are included with the mount, and the cable connects directly to the capture port of the VEO. The recommended position is on the side of the camera, as shown.



Phantom VEO 640S

Pictured with Cine Essential Kit and on-board 12V Anton Bauer Gold mount. Lens, Matte Box and Rods are not included.

Viewfinder and Monitor Options



Phantom VEO cameras come standard with an SDI Din, HDMI and a 4-pin Hirose 12V VF Power output, which supports small, low power monitors and viewfinders. The VF output is specified for devices up to 0.9 amp (10W when the camera is running from a 12V power source). Larger, higher power devices must be powered from a separate source.

Vision Research offers a few different VF power cables for on-camera monitors including:

Hirose to 2-pin Lemo. This is for monitors and viewfinders with a 2-pin Lemo input.

Hirose to XLR4 15 inch cable. This is for monitors with a 4-pin XLR input for power.



VEO cameras ship standard with a 12 inch SDI Din port which is perfect for on-camera SDI monitors and viewfinders, like the one pictured at left. The SDI Din cable is included in the camera's ship kit.

Recommended Viewfinder



Zacuto's Gratical Eye Viewfinder is a great eyepiece solution for the Phantom VEO. It features a high quality OLED display, intuitive menu system and is small and lightweight.

Vision Research offers a kit that includes a viewfinder bracket and the necessary cables to connect the Gratical Eye to Phantom VEO cameras. Part # VRI-ZACUTO-VF-EYE-KIT

Lens Mounts

One of the main differences between the original VEO and VEO4K models are the lens mounts that they use. VEO 340, 640, 410 and 710 models use the same exact mounts and OLPF as Miro R/LC/Lab cameras.

VEO4K PL, 590 and 990 models use the same mounts and OLPF as the Flex4K, except for the C-mount which is specific to the VEO4K. The Canon mount requires the addition of a pin adapter (if mount is purchased with the VEO4K part number the adapter is included).



VEO4K 990S with Nikon mount (left)
and **VEO640S** with Canon mount (right)

Mount Options and Description

Nikon mounts are compatible with both manual F-mount and newer G-style lenses. A mechanical lever on the front of the mount allows for manual adjustment of the aperture on G-style lenses.

Canon mounts work with electronic Canon EOS lenses and allows for control of aperture (on-camera and in software or remote control) and focus (in software or remote control). While most Canon lenses are supported, it is a good idea to check that your lens has been verified on the Vision Research website www.phantomhighspeed.com. Verified lenses can be found in the FAQs in the support section of the website.

Optical Low Pass Filter (OLPF)

Installing a New Lens Mount

PL mounts are compatible with a wide array of manual cinema PL lenses.

A C-mount is often required for specialized optics such as microscope mounts for scientific imaging or small rugged lenses for crash test applications. To install the C-mount on a VEO4K camera, the mount ring connected to the camera body must first be removed. Other mounts are fastened directly onto the attached mount ring.

The Optical Low Pass Filter (OLPF) for color VEO 340 and 640 camera models is designed for a 10-micron pixel and exists to reduce aliasing caused by the Bayer pattern of the sensor. It is recommended for cinema applications. The OLPF is mounted to a circular disc that is easily installed under the lens mount along with the lens shims. Part # VRI-VEO-X40-OLPF-BG

The OLPF for the VEO4K is included in VEO4K-PL models, and available as an accessory for color 990 and 590 models. This OLPF attaches to the camera body in front of the sensor with 2 screws. Back focus must be adjusted after installation. Part # VRI-F4K-OLPF

Installing a new lens mount is simple. Remove the four screws that are attaching the current lens mount (either M2.5 or M3 depending on model). Ensure all shims that are behind the mount are transferred to the new mount.

In the case of the Canon mount, ensure the camera is powered down and carefully align the pins to the plug found behind the mount. The VEO4K requires the added pin adapter for connection. Once lined up, use the same screws to fasten the new mount in place.



Any time the lens mount is removed it's important to verify the back focus. A set of extra lens mount shims is included with every VEO lens mount in order to adjust the camera's back focus when necessary.

WiFi Dongle for USB Port



VEO S-model cameras must be running a minimum firmware version 106 for the wireless functionality to work with a USB WiFi adapter attached to the camera's USB port. The USB adapter must support 802.11g protocol and it must have an RT5370 chipset for compatibility. Contact your Vision Research representative for recommendations, or purchase with part # VRI-USB-WIFI

To operate, the camera must be booted with the USB adapter installed.

Once connected, the WiFi network will be visible as "Phantom VEO..." followed by the camera model and serial number.

The password for this is: **CameraConnect**

The camera can now be controlled wirelessly on a laptop computer or using the excellent (3rd party) iPhantom IOS app.

CFast Cards and Reader

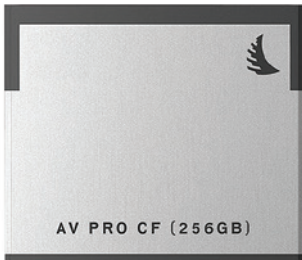

Part #s

VRI-CFAST-128 (also available in 256 and 512 GB).

Formatted CFast 2.0 cards VRI-CFAST-READER-USB3:

A simple USB3 reader for CFast 2.0 cards.

Phantom VEO S-model cameras include compatibility with CFast 2.0 cards. At the time of writing, Vision Research has verified cards manufactured by Angelbird and Lexar.

VEO cameras require the card to be formatted for the NTFS file system. More information about formatting the cards and working with CFast cards can be found in Chapter 5 of this manual.

Transport Case

The popular Pelican 1510 case is the perfect size for a Phantom VEO camera and a set of accessories. Vision Research offers this case with custom foam that includes space for the camera body, with or without handle and cheese plate, plus the cable kit, small monitor, and a few extras such as lens mounts or battery mounts. It is a very convenient size with wheels and a handle.

Case dimensions: 22.0 x 13.8 x 9.0"
(55.9 x 35.1 x 22.9 cm)

Part numbers:

VRI-CASE-VEO (black)

VRI-CASE-VEO-TAN (desert tan color)

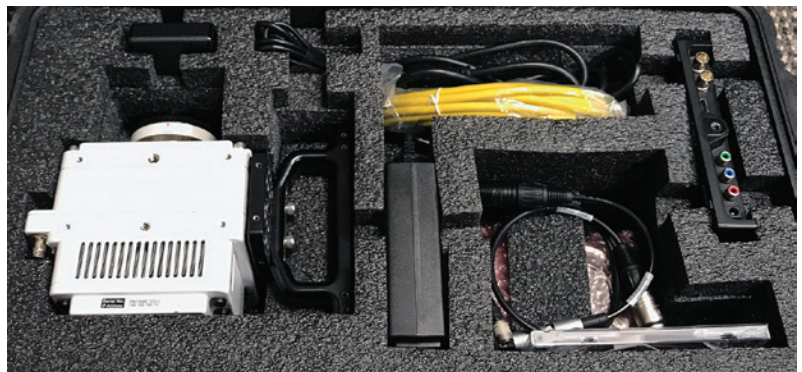
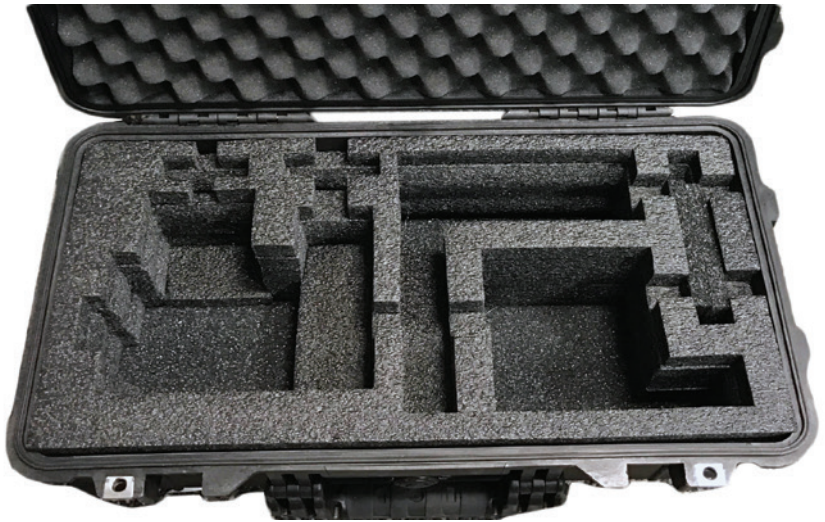

Junction Box

The updated Phantom Miro JBox 2.0 (JB2) can manage up to 4 VEO-S camera models at once. The JB2 receives one power input, and in turn powers and synchronizes each connected camera with a combined system + adapter cable as pictured. A single Ethernet cable from the JB2 can connect to PCC for control and download. The JB2 is compatible with Miro C, N, R, LC and all VEO S-model cameras (not L).



mechanical drawings

VEO S-model
Front/Back

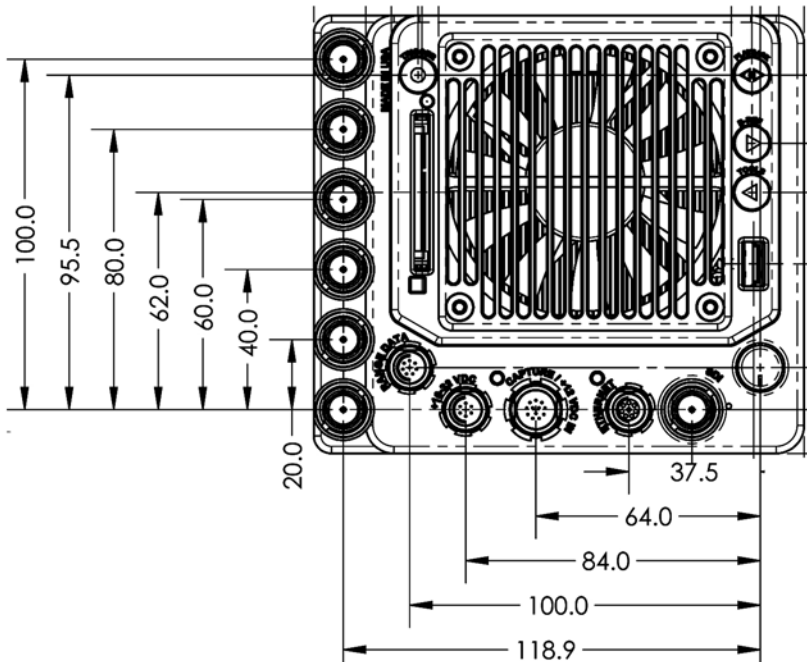
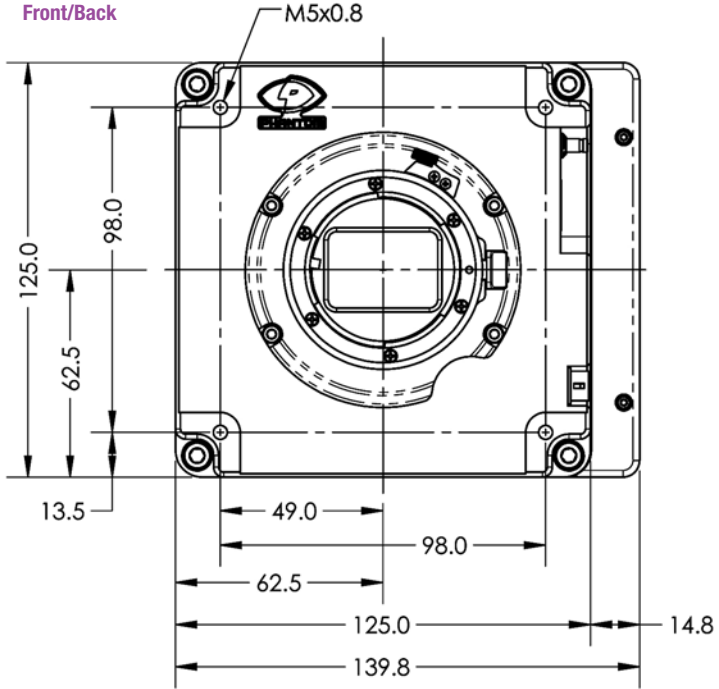

10

Support

VEO S-model
Top/Bottom

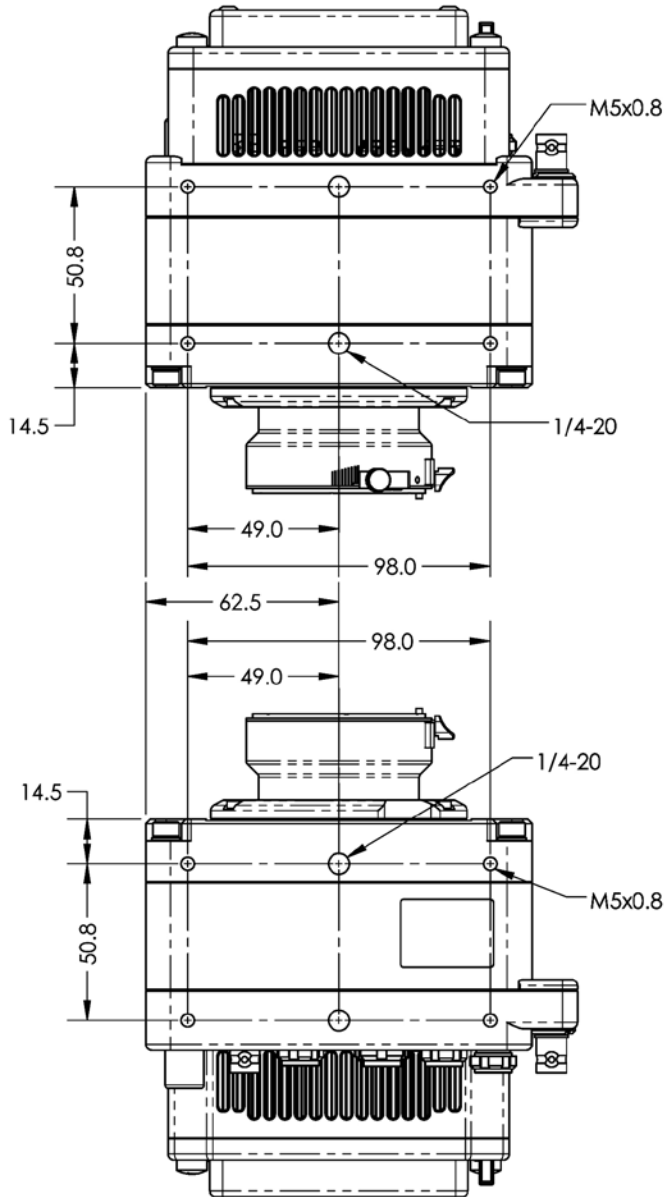

VEO S-model
Left/Right

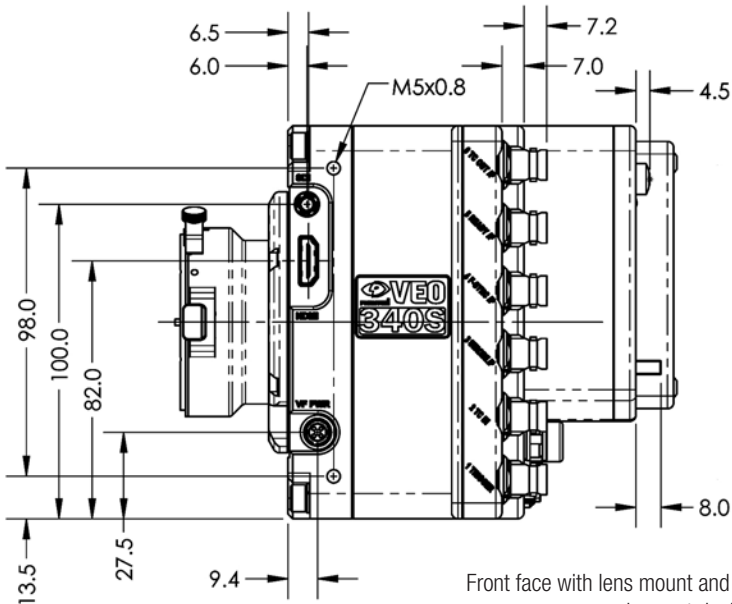
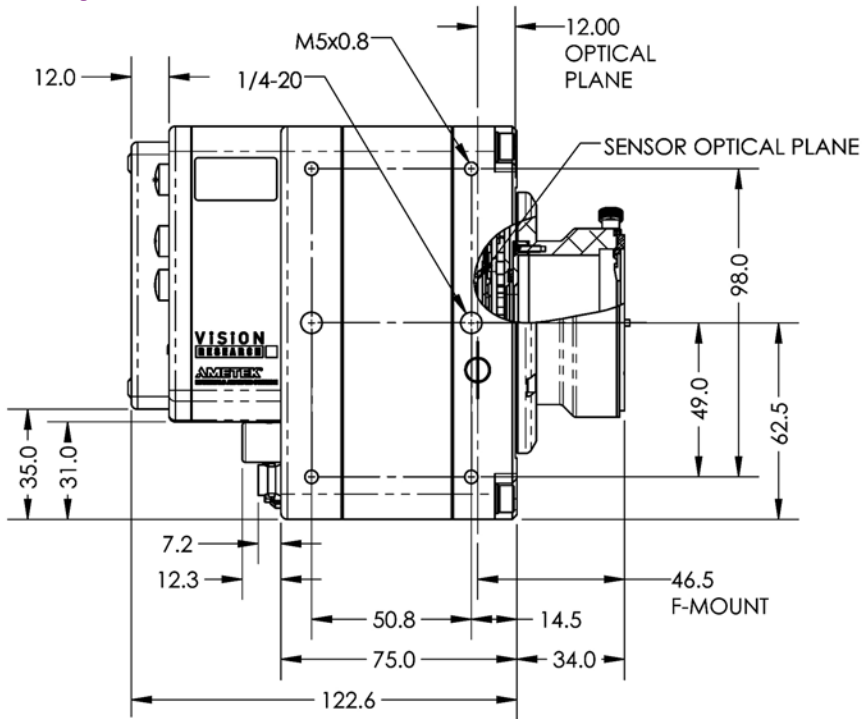

Front face with lens mount and optical plane info
does not depict VEO4K models

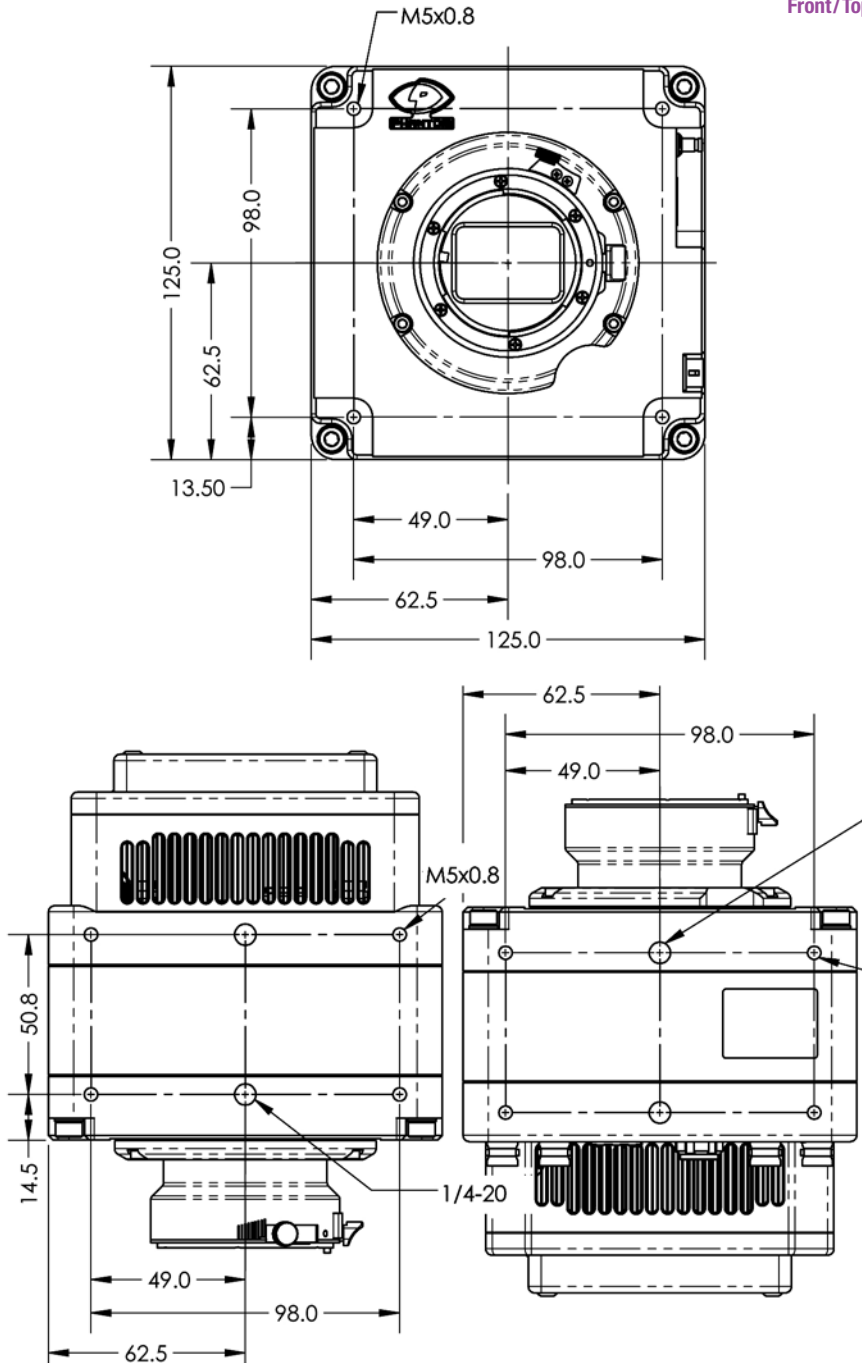

**VEO L-model
Side/Back**



These drawings represent VEO x40 and x10 models. VEO4Ks are very similar but have a different front section with lens mount. Refer to the VEO4K product pages at www.phantomhighspeed.com for complete external drawings.

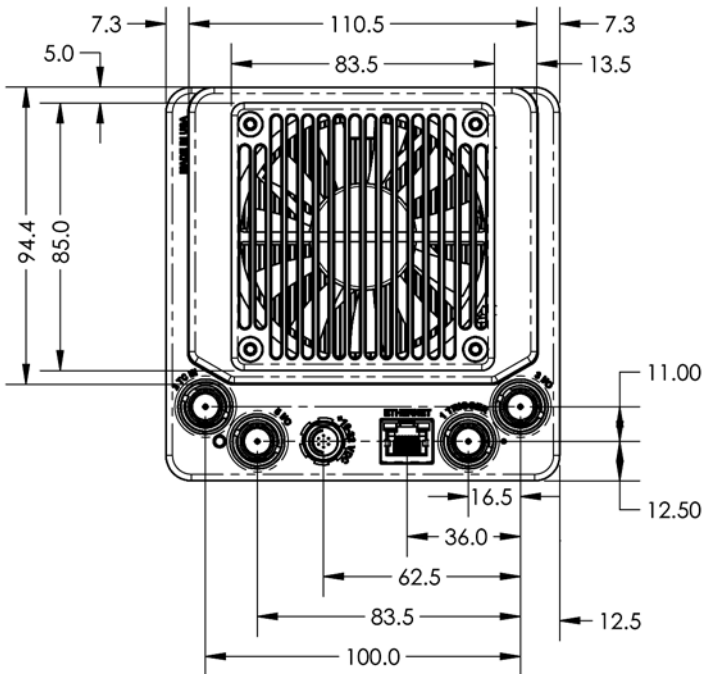
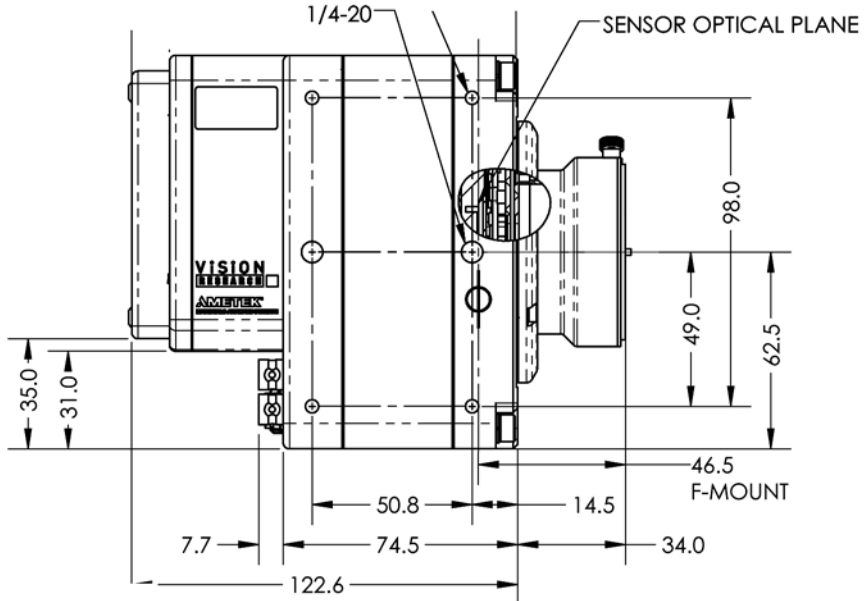



Use these schematics to build custom cables at your own risk. Mis-wired cables can cause serious damage to the camera, which is not covered under warranty. Vision Research recommends only using cables supplied by Vision Research.



These pin-out diagrams refer to the connector on the camera body. Part numbers indicated are for the cable's connector.

6-Pin Power +16-28VDC (Male)



Main power port. VEO S and L models
6-pin Fischer part # SS 103 Z 056 1300

PIN	NOMENCLATURE / FUNCTION
1	PGND / Power Ground
2	VDC +16-28 VDC (Direct Current)
3	RxD1 / RS-232 Receive Data 1
4	TxD1 / RS-232 Transmit Data 1
5	UNUSED
6	GND / Ground

4-pin 12V Viewfinder Power (Female)



12V Viewfinder power. VEO S and L models
4-pin Hirose part # HR10A-7P-4P

PIN	NOMENCLATURE / FUNCTION
1	GND Chassis Ground
2	RTALLY Red Tally
3	GTALLY Green Tally
4	+12 VDC / up to 1.5 Amps

8-pin Ethernet (Female)



Ethernet port. VEO S models only
8-pin Fischer part # S-103-A-058-130

PIN	WIRE	NOMENCLATURE / FUNCTION
1	Blue/White	MDI2P Media Dependent 2 Positive
2	Blue	MDI2N Media Dependent 2 Negative
3	Brown/White	MDI3P Media Dependent 3 Positive
4	Brown	MDI3N Media Dependent 3 Negative
5	Green/White	ETHRXP Ethernet Receive Positive
6	Green	ETHRXN Ethernet Receive Negative
7	Orange/White	ETHTXP Ethernet Transmit Positive
8	Orange	ETHTXN Ethernet Transmit Negative

8-pin Range Data (Male)



Range Data port. VEO S models only
8-pin Fischer part# S103Z05813

PIN	NOMENCLATURE / FUNCTION
1	GND / Power Ground
2	ROUT+ / Remote/Range Data Out (Positive), (RS-422); +5V maximum. Depending on data transmission rates, RS-422*
3	ROUT- / Remote/Range Data Out (Negative), (RS-422); +5V maximum. Depending on data transmission rates, RS-422
4	RIN+ / Remote/Range Data In (Positive), (RS-422); +5V maximum. Depending on data transmission rates, RS-422
5	RIN- / Remote/Range Data In (Negative), (RS-422); +5V maximum. Depending on data transmission rates, RS-422
6	+3V3R
7	+24VR
8	GND / Power Ground

* RS-422 up to 4,000 feet (1,275 meters).

12-pin Capture (Male)



Capture port for optional mini-bob and 12V power input
VEO S-models only

12-pin Fischer part # S-1031-Z012-130

PIN	NOMENCLATURE / FUNCTION
1	I0GND Signal ground
2	I0GND Signal ground
3	I0GND Signal ground
4	TRIGGER Isolated Input. Active low. Can be activated by a switch to ground. Pulse must be at least 3 microseconds long.
5	P/I0 5 (Programmable) default signal is READY
6	P/I0 6 (Programmable) default signal is STROBE
7	TCIN Timecode Input can accept IRIG-B and SMPTE standards
8	GND
9	TCIN Timecode Input can accept IRIG-B and SMPTE standards
10	POWER / Nominal power supply voltage is +24VDC (acceptable range is 12-36VDC)
11	POWER / (see Pin 10)
12	P/I0 6 (Programmable) default signal is TIMECODE OUT

How is the light sensitivity determined?

We test our cameras' light sensitivity to an industry standard: ISO 12232. We use the SAT method which we think is the best method for determining a sensor's sensitivity. The SAT method does not use gain to boost sensitivity. When using gain to increase sensitivity, you also boost the noise level. Note that a gain adjustment, and other image processing tools to boost sensitivity are available on all Phantom cameras.

How does the Exposure Index work?

Exposure Index is an image processing adjustment to change the "effective ISO" for use when determining exposure and lighting. It works by applying a pre-defined tone curve to the image. This boosts the signal in a non-linear way in order to get the most out of the sensor's inherent dynamic range.

The exposure index (EI) range always starts at the camera's base ISO level and goes up from there. Just like any digital camera, the higher the value, the more noise - however overall image degradation is noticeably less than when compared to a linear gain adjustment.

The highest pre-set EI setting has been selected to ensure image quality looks good throughout the range. Additional image processing can be added beyond that pre-set. This produces a "Combined EI" value which is shown on the camera's on-screen-display (OSD) and in PCC software. The combined EI is what should be used for lighting and exposure calculations.

What is a Current Session Reference (CSR) and When should I use it?

Phantom cameras employ CMOS sensors, which are made up of thousands of pixels whose sensitivity can drift due to changes in resolution, exposure, time and temperature. A Current Session Reference calibrates all the pixels that will be used for a given set of camera parameters. It is good practice to perform a CSR when the camera boots up and after any settings changes to ensure the best possible images.

Phantom VEO cameras include a built in mechanical shutter that automatically closes during the CSR, which only takes a second. Auto-BREF can be set in the software, or via the on-camera menu, so that whenever the camera enters capture mode it will close the shutter and do the CSR.

What is the difference between Global and Rolling Shutter modes with the VEO4K?

VEO4K models can operate with a global shutter (GS) or rolling shutter (RS). The sensor mode can be switched using PCC software or the On-Camera control menu. GS mode may be necessary when the images are being used for measurements, when synchronizing to light sources and when known rolling shutter artifacts are anticipated. There are differences in terms of overall image quality that are important to understand:

In **Rolling Shutter** mode the VEO4K produces images with 12.5 stops of dynamic range and a base ISO of 320 (color cameras). The low noise means the image can be pushed to about 1250 using the Exposure Index function, with good results.

In **Global Shutter** mode the same camera the dynamic range drops to about 9 stops, and the base ISO raises to 640 (color). There is a higher amount of noise, so Vision Research only recommends pushing the image to about 1250 when possible. In GS mode there is a greater need to perform a Black Reference (aka CSR) before capturing the shot.

Also keep in mind that the VEO4K only supports “**PIV mode**” when set to GS mode. When enabled this keeps the exposure at the maximum value and shortens the straddle time between frames for PIV applications.

What remote control options are there for VEO?

The Phantom RCU has not been updated to work with VEO, and is therefore not recommended. However, if one was to have an RCU with appropriate cables (same as Miro RCU connection kit), it would still control the basic capture, trigger and save functionality. The addition of a **VEObob** (CAMEO accessory) includes a ‘remote’ port for compatibility to a Bluetooth dongle. The VEObob also opens up compatibility with the Abel Cine Phantom **PCU**.

Starting with firmware version 106, VEO S-model cameras support **WiFi control** through a USB WiFi adapter. The USB adapter must have an RT5370 chipset for compatibility. Contact Vision Research for recommendations or purchase with part# VRI-USB-WIFI. Please note, the camera must be booted up with the USB adapter installed, And the password is “CameraConnect”. This opens up connectivity to the 3rd party **iPhantom** app for IOS devices.

**What video modes are supported?
Does the VEO support
NTSC/PAL video?**

**How long does it take
to save from the camera vs
from the CFast card?**

Another solution for remote (wired or wireless) control is the 3rd party “**Semote**” controller. This allows for wireless connectivity over the longest range when compared to the other identified solutions, and includes compatibility with all Ethernet-based modern Phantom cameras.

The SDI and HDMI outputs found on all Phantom VEO cameras are 3G and support the common 720p and 1080p 3G signals. The camera supports:

4:2:2 1.5G 1080p/psf/i at 23.9, 24, 25, 29.9 Hz;
720p at 50, 59.9 Hz

4:2:2 3G 1080p 50 and 59.9 Hz

VEO cameras do not include NTSC or PAL outputs.

When connected via Ethernet, it is faster to save from RAM directly than it is to save Cine files stored on a CFast card. The time it takes to download Cine files over Ethernet (Gb or 10Gb) is highly dependent on the computer system and the hard drive being used. For example, a solid state drive will always achieve higher rates than traditional hard drives. From RAM, on an optimized system it is possible to achieve 70-80 MB/ sec over Gb Ethernet, and 400-500 MB/sec using 10Gb Ethernet.

The save rate from RAM to CFast 2.0 is approximately 90 MB/second. An entire 72GB RAM cine file will take approximately 12 minutes to complete the save. It is always recommended to review the shot and set in and out points prior to beginning the save to optimize time and card space.

It is true that CFast is capable of faster data throughput. The main reason the VEO bandwidth is limited is due to the in-camera processing required to convert raw data to a wrapped Cine file. It is worth noting that the save time from the CFast 2.0 card using a reader (whether USB3 or Thunderbolt) is much faster than downloading over Ethernet.

basic troubleshooting

There are fixed black spots on the image, particularly at small apertures.

The live images look scrambled and the frame rate can't be set

Restoring the factory defaults

The EOS mount is not working on a VE04K

This is most likely caused by dust particles stuck on the sensor or OLPF (optical low pass filter) surface. The best way to check is to remove the lens and look at the glass surface with a bright light source. Vision research recommends not to use canned air to clean the sensor surface. It is safer to use a manual bulb-style air blower and/or sensor cleaning brush for removing loose dust particles.

Additional tips for cleaning sensors can be found in the maintenance section of this manual.

If the image is non-responsive and scrambled, the camera may be set to an external sync without a sync source connected. Check the Sync setting (advanced settings in PCC, or via the on-camera control menu) to ensure that 'Internal' is selected.

If the camera is stuck in an unusual state it may be useful to restore the camera's factory defaults. This returns the capture parameters, image processing, video modes, and image calibration back to the original settings.

Factory Defaults can be set in the Nucleus program within PCC, or via the 'Settings' menu of the OCC. Select 'Factory defaults' / 'OK'. It will take approximately 20 seconds for the camera to return to an operational state.

VE04K cameras use the same Canon mount as the Phantom Flex4K. This mount has pins on the back, which must be extended to meet the port on the front of the camera. When purchasing the mount using the VE04K part number, a pin adapter is included. When using the same mount as the Flex4K, the adapter can be purchased with part # VRI-ADAPT-FLEX4KEOS-VE04KEOS.

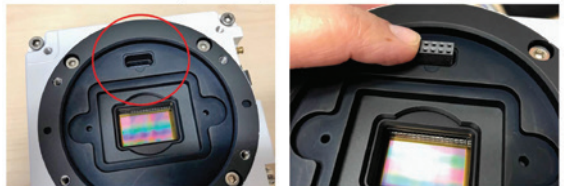

Note that VEO x10 and x40 models use a different style Canon mount (the same one as Miro cameras).

Sensor & OLPF Cleaning Technical Tips

- Sensor cleaning should only be attempted by experienced imaging professionals.
- Use a small, but powerful flashlight to look at the sensor and filter, it's easier to spot the dust.
- The OLPF assembly is removable and located in front of the sensor. Once the lens mount is uninstalled the OLPF can be easily removed for cleaning.
- Sensor cleaning must be done in a clean and controlled environment
- Always have a forced-air bulb style blower and a clean sensor cloth handy for more serious dirt.
- Sensor cleaning solution (like Eclipse) should only be used if absolutely necessary, and applied with a soft wipe intended for sensor cleaning.
- Cotton swabs aren't a good idea, unless they are wrapped in a sensor wipe material. They leave behind more than they remove.
- Never use your finger to get a speck of dust off, it's going to make things much worse.
- Never blow on the sensor or OLPF.
- Never put sharp objects near the surface of the OLPF or sensor.
- Always keep the Phantom body cap on the camera when there is no lens attached.

Back Focus Adjustment

Due to differences in various lenses and other mechanical tolerances it may be necessary to adjust the lens mount on the camera to obtain proper focus. In most cases, changing a lens or replacing a mount will not require adjusting the back focus, though it should be verified. When the focus distance marks on a lens do not match the measured distance between the sensor & subject, it indicates the need to adjust the back focus.

By adjusting the back focus, you are changing the distance of between the flange and the sensor plane. Shims are included to assist in both slight and coarse backfocus adjustments.

Global Headquarters

Vision Research, Inc. - Wayne, New Jersey

100 Dey Road
Wayne, New Jersey 07470 USA

T: +1.973.696.4500

For answers to most questions, please visit us at:
www.phantomhighspeed.com and search the camera product pages, tutorials, support knowledgebase, and FAQs.

Submitting a Support Ticket

For technical product support, operation, application info or to request an RMA please submit a ticket by filling out a form at www.phantom-service.force.com or by emailing us at phantom-support@ametek.com.

Live Customer and Technical Support

Serving the Americas:

M-F 8:00 AM to 5:00 PM EST (GMT-4:00)

T: +1.973.696.4500

Customer Support, extension 4002

Technical Support, extension 4003

Serving Europe, the Middle East and Africa:

M-F 9:00 AM to 6:00 PM GMT +3:00

Vision Research, Inc. - Bucharest, Romania

T: +40 21 210 8587

Serving Asia Pacific

M-F 8:00 AM to 5:00 PM GMT +8:00

Vision Research, Inc. - Shanghai, China

T: 86-21- 58685111, ext:141



CE - 2016

Phantom VEO products are in compliance with the requirements of the Low Voltage Directive (LVD) 2014/35/ EU, the Electromagnetic Compatibility (EMC) Directive 2014/30/EU and the Federal Communications Commission (FCC) CFR 47, Part 15 at the time of product manufacture and carries the CE-marking.



KC - 2016

Vision Research
Approval Issue: November 2016
Country of Origin: USA

MSIP-REM-VRi-Phantom-VEO-L

VEO-710L, VEO-640L, VEO410L and VEO340L

MSIP-REM-VRi-Phantom-VEO-S

VEO-710S, VEO-640S, VEO410S and VEO340S

For Class B devices:

이 기기는 가정용(B급) 전자파적합기기로서 주로 가정에서 사용하는 것을 목적으로 하며, 모든 지역에서 사용할 수 있습니다.

Translation: Class B device (Broadcasting Communication Device for Home Use): This device obtained EMC registration mainly for home use (Class B) and may be used in all areas.

KC - 2017

Vision Research
Approval Issue: December 2017
Country of Origin: USA

R-REM-VRi-VEO4K-L: VEO4K-990L, VEO4K-590L

R-REM-VRi-VEO4K-S: 4K-990S, 4K-590S, 4K-PL

For Class A devices:

이 기기는 업무용(A급) 전자파 적합기기로서 판매자 또는 사용자는 이 점을 주의하시기 바라며, 가정외의 지역에서 사용하는 것을 목적으로 합니다.

Translation: Class A device (Broadcasting Communication Device for Office Use): This device obtained EMC registration for office use (Class A), and may be used in places other than home. Sellers and/or users need to take note of this.

KC Mark Location

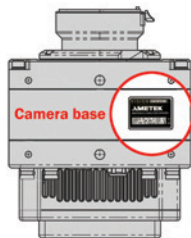

**Change Log for VEO Manual
Rev B**

- Added VEO4K (590, 990, PL) product information
- Added 10Gb Ethernet networking guide
- Added new on-camera menu parameters relating to VEO4K models
- Added info about the USB WiFi dongle and relevant settings

www.phantomhighspeed.com

Vision Research - Corporate Headquarters
100 Dey Road
Wayne, New Jersey 07470
USA
Ph: +1.973.696.4500
Fax: +1.973.696.0560